



Power Transmission Belt Drive System

Installation, Maintenance and
Troubleshooting Guide

Table of Contents

Installation

V-Belts

V-Belts	3
---------	---

Banded Belts

Torque Team® V-Belts	16
Poly-V® Belts	25

Specialty Belts

Variable Speed Belts	33
----------------------	----

Synchronous Belts

Synchronous Belts	35
-------------------	----

Maintenance

What to look for	44
What to listen for	45

Troubleshooting

V-Belts Performance Analysis	46
V-Belts Troubleshooting Chart	49
Synchronous Belts Troubleshooting Chart	51
Synchronous Belts Tensioning Tables	53
Wedge TLP™ V-Belts Tensioning Tables	54
V-Belts Tensioning Tables	55
Tools	58

Poly-V and Torque Team are registered ® trademarks of Continental ContiTech.



V-Belts

Installation Guide

Check sheaves for cleanliness, damage and wear each time belt maintenance is performed and whenever belts are changed. The inspection procedure is described on page 7 of this guide.

Use the Groove Dimensions Tables 1 and 2 (on pages 4-6) and tolerance data below as a reference to determine if excessive sheave wear has occurred. They can also aid in replacement belt cross section selection, if necessary.

The tables are based on industry standard dimensions for V-belt sheaves. Always check the original sheave specifications if possible. Variances from industry standards can occur to provide for special design or performance requirements.

Industry Standard Groove Dimensions for V-Belt Sheaves

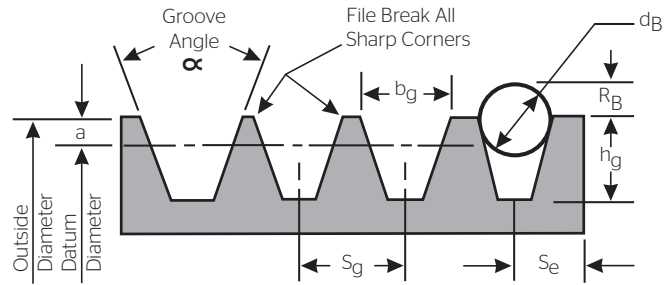

Standard Groove Dimensions

Face Width of Standard and Deep Groove Sheaves

Face Width = $S_g (N_g - 1) + 2 S_e$
Where: N_g = Number of Grooves

Table 1 Groove Dimensions

Standard Groove Dimensions (in.)										
Cross Section	Outside Diameter Range	Groove Angle α ± 0.33	b_g	b_g	h_g Min.	R_B Min.	d_b ± 0.0005	S_g ± 0.025	S_e	S_e
A, AX	Up through 5.65	34	0.494							
	Over 5.65	38	0.504	± 0.005	0.460	0.151	0.4375			+0.090
B, BX	Up through 7.35	34	0.637							
	Over 7.35	38	0.650	± 0.006	0.550	0.192	0.5625			+0.120
A, AX & B, BX Combination	Up through 7.4	34	0.612							
		38	0.625	± 0.006	0.612	0.233	0.5625			+0.120
	Over 7.4	34	0.612							
		38	0.625	± 0.006	0.612	0.229	0.5625			+0.120
C, CX	Up through 8.39	34	0.879			0.279				
	Over 8.39 to and including 12.40	36	0.887			0.280	0.7812			+0.160
	Over 12.40	38	0.895	± 0.007	0.750	0.282	(25/32)	1.000	0.688	-0.070
D	Up through 13.59	34	1.259			0.416				
	Over 13.59 to and including 17.60	36	1.271			0.417	1.1250			+0.220
	Over 17.60	38	1.283	± 0.008	1.020	0.418	(1 $\frac{1}{8}$)	1.438	0.875	-0.080
E	Up through 24.80	36	1.527			0.476	1.3438			+0.280
	Over 24.80	38	1.542	± 0.010	1.270	0.477	(1 $\frac{1}{32}$)	1.750	1.125	-0.090

Other Sheave Tolerances

Outside Diameter

Up through 8.0 in.
Outside diameter: ± 0.020 in.
For each additional inch of outside diameter add... ± 0.005 in.

Radial Runout*

Up through 10.0 in.
Outside diameter: ± 0.010 in.
For each additional inch of outside diameter add... ± 0.0005 in.

Axial Runout*

Up through 5.0 in.
Outside diameter: ± 0.005 in.
For each additional inch of outside diameter add... ± 0.001 in.

*Total Indicator Reading

Table 1 Groove Dimensions

Drive Design Factors (in.)			
Cross Section	Datum Diameter Range	Minimum Recommended Datum Diameter	2a
A, AX	Up through 5.40 Over 5.40	A: 3.0 AX: 2.2	0.250
B, BX	Up through 7.00 Over 7.00	B: 5.4 BX: 4.0	0.350
A, AX & B, BX Combination	A, AX Up through 7.40 (1) Over 7.40	A: 3.6 (1) AX: 2.8	0.620 (2)
	B, BX Up through 7.40 (1) Over 7.40	A: 5.7 (1) BX: 4.3	0.280 (2)
C, CX	Up through 7.99 Over 7.99 to and including 12.00 Over 12.00	C: 9.0 CX: 6.8	0.400
D	Up through 12.99 Over 12.99 to and including 17.00 Over 17.00	D: 13.0	0.600
E	Up through 24.00 Over 24.00	E: 21.0	0.800

(1) Diameters shown for combination grooves are outside diameters. A specific datum diameter does not exist for either A or B belts in combination grooves.

(2) The "A" values shown for the A/B combination sheaves are the geometrically-derived values. These values may be different than those shown in manufacturer's catalogs.

Summation of the deviations from "S_g" for all grooves in any one sheave shall not exceed ±0.050 in.

The variation in datum diameter between the grooves in any one sheave must be within the following limits: Up through 19.9 in. outside diameter and up through 6 grooves: 0.010 in. (add 0.0005 in. for each additional groove).

20.0 in. and over on outside diameter and up through 10 grooves: 0.015 in. (add 0.0005 in. for each additional groove).

This variation can be obtained easily by measuring the distance across two measuring balls or rods placed diametrically opposite each other in a groove. Comparing this "diameter over balls or rods" measurement between grooves will give the variation in datum diameter.

Deep groove sheaves are intended for drives with belt offset such as quarter-turn or vertical shaft drives. (See RMA Power Transmission Belt Technical Information Bulletin IP-3-10, V-Belt Drives with Twist).

Joined belts will not operate in deep groove sheaves.

Also, A and AX joined belts will not operate in A/AX and B/BX combination grooves.

Table 1 Groove Dimensions

Deep Groove Dimensions (in.)									
Cross Section	Outside Diameter Range	Groove α Angle ± 0.33	b _g	b _g	hg Min.	2a	S _g ± 0.025	S _e	S _e
B, BX	Up through 7.71	34	0.747	±0.006	0.730	0.710	0.875	0.562	+0.120 -0.065
	Over 7.71	38	0.774						
C, CX	Up through 9.00	34	1.066	±0.007	1.055	1.010	1.250	0.812	+0.160 -0.070
	Over 9.00 to and including 13.01 Over 13.01	36 38	1.085 1.105						
D	Up through 14.42	34	1.513	±0.008	1.435	1.430	1.750	1.062	+0.220 -0.080
	Over 14.42 to and including 18.43 Over 18.43	36 38	1.541 1.569						
E	Up through 25.69	36	1.816	±0.010	1.715	1.690	2.062	1.312	+0.280 -0.090
	Over 25.69	38	1.849						

Other Sheave Tolerances

Outside Diameter

Up through 8.0 in.

Outside diameter: ±0.020 in.

For each additional inch of outside diameter add... ±0.005 in.

Radial Runout*

Up through 10.0 in.

Outside diameter: ±0.010 in.

For each additional inch of outside diameter add... ±0.0005 in.

Axial Runout*

Up through 5.0 in.

Outside diameter: ±0.005 in.

For each additional inch of outside diameter add... ±0.001 in.

*Total Indicator Reading

V-Belts Installation Guide

Industry Standard Groove Dimensions for HY-T® Wedge Belt Drives

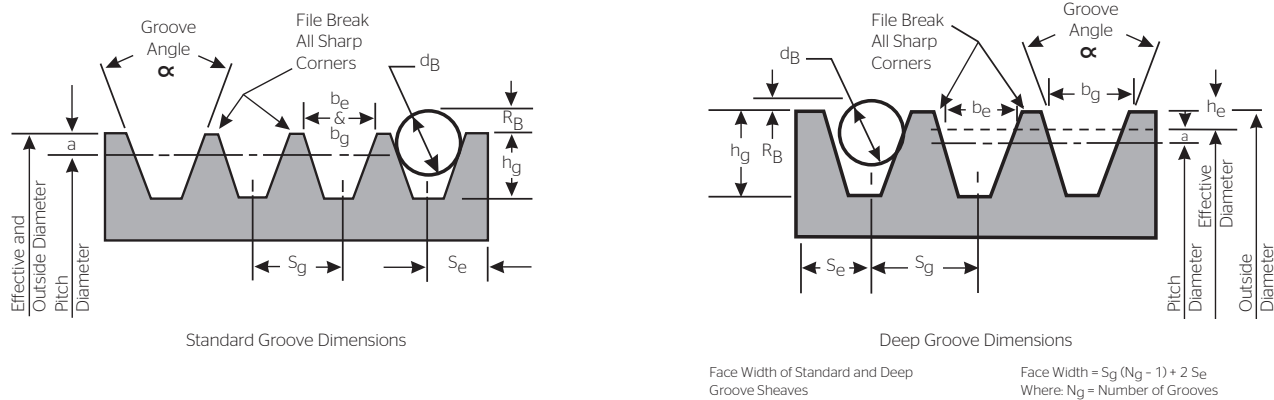

Table 2 Groove Dimensions

Cross Section	Standard Groove Outside Diameter	Standard Groove Dimensions (in.)								Design Factors		
		Groove Angle ±0.25 Degrees	bg ±0.0005	be Ref.	hg Min.	Rb Min.	db ±0.0005	Sg ±0.015	Se	Minimum Recommended Outside Diameter	2a	
3V, 3VX	Up through 3.49	36				0.181				0.344	3V: 2.65 3VX: 2.20	0
	Over 3.49 to and including 6.00	38	0.350	0.350	0.340	0.183	0.3438	0.406	+0.094			
	Over 6.00 to and including 12.00	40				0.186			-0.031			
5V, 5VX	Over 12.00	42				0.188						
	Up through 9.99	38				0.329			0.500	5V: 7.10 5VX: 4.40	0	
	Over 9.99 to and including 16.00	40	0.600	0.600	0.590	0.332	0.5938	0.688	+0.125			
Over 16.00	42				0.336			-0.047				
8V	Up through 15.99	38				0.575			0.750	8V: 12.50	0	
	Over 15.99 to and including 22.40	40	1.000	1.000	0.990	0.580	1.0000	1.125	+0.250			
	Over 22.40	42				0.585			-0.062			

Summation of the deviations from "Sg" for all grooves in any one sheave shall not exceed ±0.031 in. The variations in pitch diameter between the grooves in any one sheave must be within the following limits:

Up through 19.9 in. outside diameter and up through 6 grooves - 0.010 in. (add 0.0005 in. for each additional groove).

20.0 in. and over on outside diameter and up through 10 grooves - 0.015 in. (add 0.0005 in. for each additional groove).

This variation can easily be obtained by measuring the distance across two measuring balls or rods placed in the grooves diametrically opposite each other. Comparing this "diameter over balls or rods" measurement between grooves will give the variation in pitch diameter.

Deep groove sheaves are intended for drives with belt offset such as quarter-turn or vertical shaft drives (see Power Transmission Belt Technical Information Bulletin IP-3-10). They may also be necessary where oscillations in the center distance may occur. Joined belts will not operate in deep groove sheaves.

Other Sheave Tolerances

Outside Diameter

Up through 8.0 in.

Outside diameter: ±0.020 in.

For each additional inch of outside diameter, add... ±0.005 in.

Radial Runout*

Up through 10.0 in.

Outside diameter: ±0.010 in.

For each additional inch of outside diameter, add... ±0.0005 in.

Axial Runout*

Up through 5.0 in.

Outside diameter: ±0.005 in.

For each additional inch of outside diameter, add... ±0.001 in.

*Total Indicator Reading

Table 2 Groove Dimensions

		Standard Groove Dimensions (in.)								Design Factors		
Cross Section	Standard Groove Outside Diameter	Groove Angle ± 0.25 Degrees	$b_g \pm 0.005$	b_e Ref.	b_e h_g Min.	R_B Min.	$d_b \pm 0.0005$	$s_g \pm 0.015$	s_e	Minimum Recommended Outside Diameter	2a	2he
3V, 3VX	Up through 3.71	36	0.421			0.073						
	Over 3.71 to and including 6.22	38	0.425			0.076			0.375	3V: 2.87		
	Over 6.22 to and including 12.22	40	0.429	0.350	0.449	0.079	0.3438	0.500	+0.094 -0.031	3VX: 2.42	0	0.218
	Over 12.22	42	0.434			0.080						
5V, 5VX	Up through 10.31	38	0.710			0.172						
	Over 10.31 to and including 16.32	40	0.716	0.600	0.750	0.176	0.5938	0.812	0.562 +0.125 -0.047	5V: 7.42 5VX: 4.72	0	0.320
	Over 16.32	42	0.723			0.178						
8V	Up through 16.51	38	1.180			0.317						
	Over 16.51 to and including 22.92	40	1.191	1.000	1.262	0.321	1.000	1.312	0.844 +0.250 -0.062	8V: 13.02	0	0.524
	Over 22.92	42	1.201			0.326						

Summation of the deviations from "S_g" for all grooves in any one sheave shall not exceed ± 0.031 in. The variations in pitch diameter between the grooves in any one sheave must be within the following limits:

Up through 19.9 in. outside diameter and up through 6 grooves - 0.010 in. (add 0.0005 in. for each additional groove).

20.0 in. and over on outside diameter and up through 10 grooves - 0.015 in. (add 0.0005 in. for each additional groove).

This variation can easily be obtained by measuring the distance across two measuring balls or rods placed in the grooves diametrically opposite each other. Comparing this "diameter over balls or rods" measurement between grooves will give the variation in pitch diameter.

Deep groove sheaves are intended for drives with belt offset such as quarter-turn or vertical shaft drives (see Power Transmission Belt Technical Information Bulletin IP-3-10). They may also be necessary where oscillations in the center distance may occur. Joined belts will not operate in deep groove sheaves.

Other Sheave Tolerances

Outside Diameter

Up through 8.0 in.

Outside diameter: ± 0.020 in.

For each additional inch of outside diameter, add... ± 0.005 in.

Radial Runout*

Up through 10.0 in.

Outside diameter: ± 0.010 in.

For each additional inch of outside diameter, add... ± 0.0005 in.

Axial Runout*

Up through 5.0 in.

Outside diameter: ± 0.005 in.

For each additional inch of outside diameter, add... ± 0.001 in.

*Total Indicator Reading

V-Belts Installation Guide

1. Inspect sheaves

The following sections outline installation procedures that will ensure maximum life and performance for your V-belts.

Check sheaves for cleanliness, damage and wear whether you are replacing an existing belt, performing routine maintenance or installing a new drive.

WARNING

Disconnect power supply to the machine before removing or installing sheaves or belts.

WARNING

Do not reinstall damaged or worn sheaves on equipment.

Sheave Groove Gauge

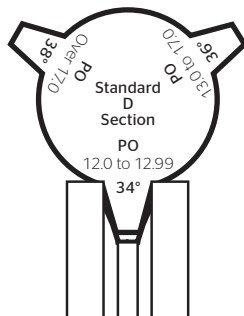

Use a stiff brush to remove rust and dirt. Use a soft cloth to wipe off oil and grease. Select the proper sheave groove gauge and template for the sheave diameter. Insert the gauge in the groove and look for voids that indicate dishing or other uneven and abnormal wear.

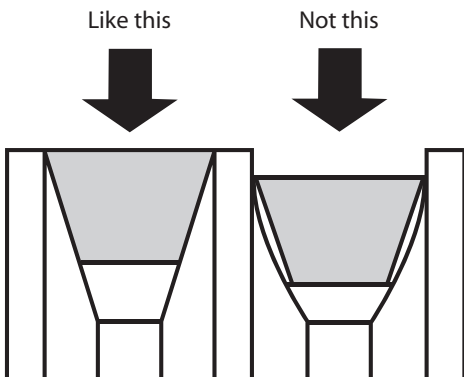

An alternative method for checking for sheave groove wear is to place a new belt in the sheave groove. Note that the top

of the belt should be flush with or slightly above the outer diameter of the sheave. Remember that if the belt top is below the sheave's outer diameter, the groove is worn. Perform further inspection if possible. Use the Groove Dimension Tables 1 and 2 (on pages 3-6) to determine if excessive wear has occurred or to select replacement belts and sheave cross sections.

2. Install hardware

Always remember to select the correct sheave. Then, after you make the correct selection, be sure to install the sheaves correctly.

Before performing any installation, follow correct lockout procedures to prevent any accidents.

IMPORTANT: Disconnect power supply to machine **before** doing ANY work.

QD® Bushing (Conventional Mount)

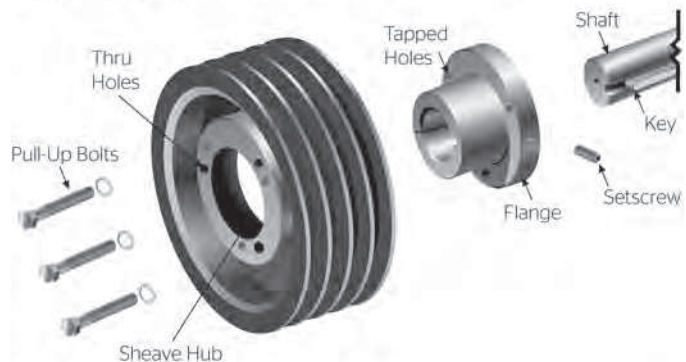

*QD® is a registered trademark of Emerson Power Transmission Manufacturing, L.P.

QD® Bushing

If the sheaves are made with a QD® hub, follow these installation and removal instructions:

3. How to install a sheave with a QD® hub

Insert the bushing in the hub and line up bolt holes.

Insert the pull-up bolts and turn until finger tight.

Hold the loosely-assembled unit so the bushing flange points toward the shaft bearings. Reverse mounting the QD® bushing can be advantageous for some applications.

Slip the unit onto the shaft and align the hub in the desired position.

Tighten the setscrew in the flange only enough to hold the assembly in position.

Tighten each pull-up bolt alternately and evenly.

Recheck alignment and completely tighten the setscrew on the shaft.

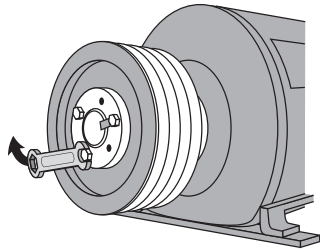

4. How to remove a sheave with a QD® hub

Place two of the pull-up bolts in the tapped holes in the sheave.

Turn the bolts alternately and evenly. They will push against the bushing flange and act as jackscrews to break the grip between the bushing and the hub.

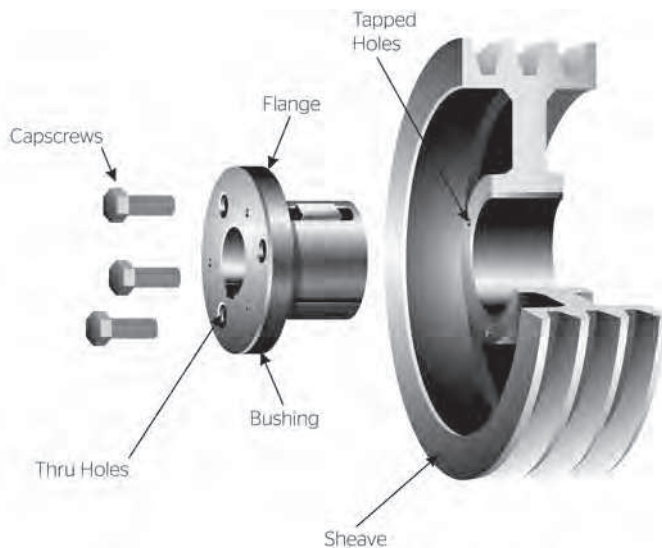

Split Taper Bushing

If the sheaves are made for split taper bushings, follow these installation and removal instructions:

5. How to install split taper bushing sheaves

Put the bushing loosely in the sheave and start the capscrews.

Place the assembly on the shaft. Align both edges of the sheave with the edges of its mating sheave (example: the sheave on the driven shaft).

Tighten the capscrews according to the instructions furnished with the bushings.

6. How to remove split taper bushing sheaves

Remove all capscrews.

Put two of the capscrews in the tapped holes in the flange of the bushing.

Turn the bolts alternately and evenly until the sheave has loosened.

Remove the sheave/flange assembly from the shaft.

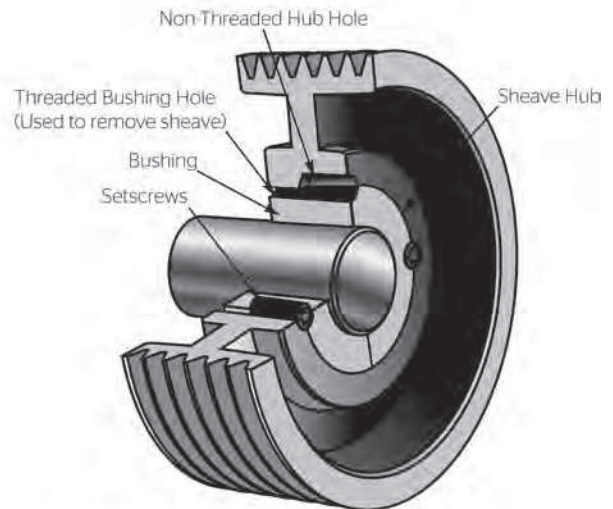

*Taper-Lock: TM Reliance Electric Company

Taper-Lock Bushing

7. How to install a sheave made with a taper-lock hub

Look at the bushing and the hub. Each has a set of half-holes. The threaded holes in the hub are the mates to the non-threaded holes in the bushing.

V-Belts Installation Guide

Insert the bushing in the hub and slide it onto the shaft. Align a threaded hub hole with non-threaded bushing hole.

Start the setscrews into the holes that are threaded in the hub only. Do not tighten the setscrews yet.

Align both edges of the sheave with the edges of its mating sheave.

Tighten the screws alternately and evenly. This procedure will wedge the bushing inward and cause it to contract evenly and grip the shaft.

8. How to remove a sheave made with a taper-lock hub

Remove all the setscrews.

Place two of the setscrews in the holes that are threaded in the bushing only.

Turn the setscrews alternately and evenly. This movement will unlock the grip and permit easy removal of the assembly with no shock to the bearings or machinery.

9. Check alignment

Proper alignment is essential for long V-belt life. Check belt alignment whenever you maintain or replace belts or whenever you remove or install sheaves. Limit misalignment to 1/2 degree or approximately 1/10 inch per foot of center distance.

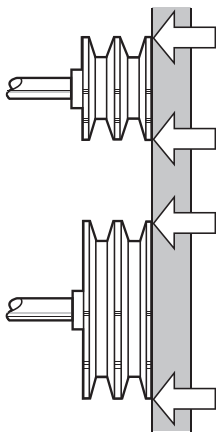

The illustration above shows the correct way to check alignment between two sheaves with a straight edge. Check both front and back alignment. Straight edge should touch sheaves at the four points indicated.

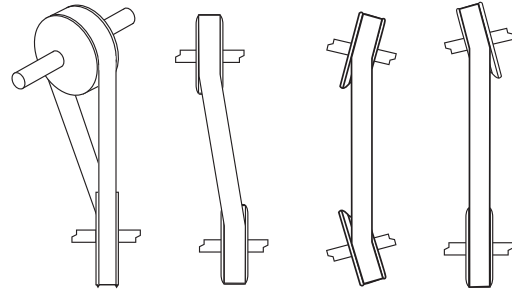

Non-parallel shafts or sheaves not aligned axially can cause angular misalignment.

Laser Alignment Tool

With our Laser Alignment Tool, you can quickly align drive components to improve efficiency and reduce costly maintenance. Much easier to use than a straight edge, it attaches in seconds and when the highly-visible sight line lies within the target openings, the pulley/sprockets are aligned.

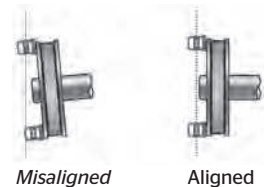
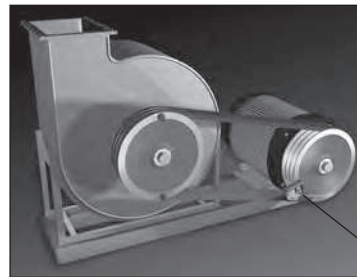

10. Identify correct belt

Always select belts to match sheave grooves. Use a sheave groove gauge to determine the proper belt cross section (Figure A).

Use a belt gauge to verify the old belt cross section when belt identification is no longer legible (Figure B).

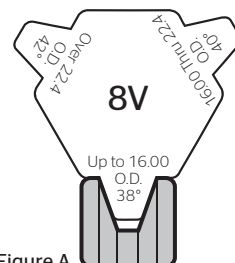

Figure A

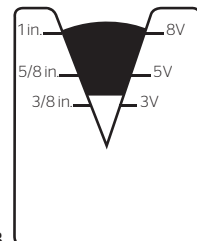
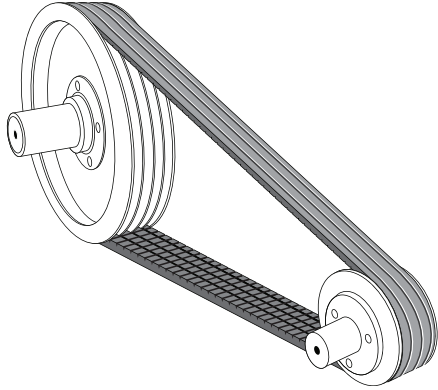

Figure B

11. Matching belts

When using multiple grooved sheaves, be sure that all of the belts are the same brand. Always replace complete sets of V-belts even if only one is worn or damaged.



Never force belts into a sheave with a tool such as a screwdriver or a wedge. Doing so may rupture the envelope fabric or break the cords.



12. How to install belts

After you correctly install and align the sheaves, you can install the belts.

Always move the drive unit so you can easily slip the belts into the grooves without force.



Refer to Tables 3 and 4 (below and page 11) to determine if enough clearance exists for belt installation and take-up.

For example, if you are installing a B75 HY-T® Plus belt, the minimum allowable center distance for installation is 1.25 inches. For belt take-up, the minimum allowance above center to maintain tension is 2 inches.

Shorter Center Distance for V-Belt Installation

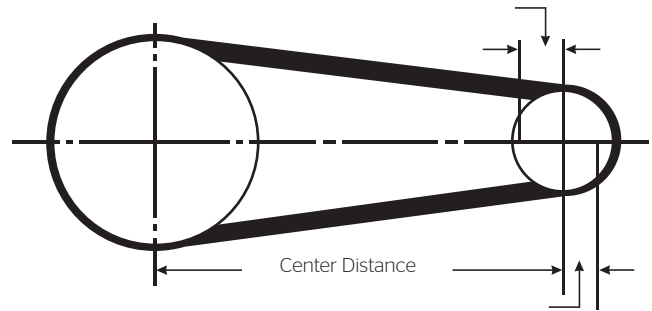

Longer Center Distance for V-Belt Take-Up

Table 3 HY-T® Plus V-Belts

Standard Length Designation	Minimum Allowance Below Standard Center Distance for Installation of Belts (in.)								Minimum Allowance Above Standard Center Distance for Maintaining Tension All Cross Sections
	A	B	B Torque Team®	C	C Torque Team®	D	D Torque Team®	E	
Up to and including 35	0.75	1.00	1.50						1.00
Over 35 to and including 55	0.75	1.00	1.50	1.50	2.00				1.50
Over 55 to and including 85	0.75	1.25	1.60	1.50	2.00				2.00
Over 85 to and including 112	1.00	1.25	1.60	1.50	2.00				2.50
Over 112 to and including 144	1.00	1.25	1.80	1.50	2.10	2.00	2.90		3.00
Over 144 to and including 180		1.25	1.80	2.00	2.20	2.00	3.00	2.50	3.50
Over 180 to and including 210		1.50	1.90	2.00	2.30	2.00	3.20	2.50	4.00
Over 210 to and including 240		1.50	2.00	2.00	2.50	2.50	3.20	2.50	4.50
Over 240 to and including 300		1.50	2.20	2.00	2.50	2.50	3.50	3.00	5.00
Over 300 to and including 390				2.00	2.70	2.60	3.60	3.00	6.00
Over 390				2.50	2.90	3.00	4.10	3.50	1.5% of belt length

V-Belts

Installation Guide

Table 4 HY-T® Wedge and Wedge TLP™ V-Belts

Standard Length Designation	Minimum Allowance Below Standard Center Distance for Installation of Belts (in.)						Minimum Allowance Above Standard Center Distance for Maintaining Tension All Cross Sections
	3V, 3VT	3V Torque Team®	5V, 5VT	5V Torque Team®	8V, 8VT	8V Torque Team®	
Up to and including 475	0.5	1.2					1.0
Over 475 to and including 710	0.8	1.4	1.0	2.1			1.2
Over 710 to and including 1060	0.8	1.4	1.0	2.1	1.5	3.4	1.5
Over 1060 to and including 1250	0.8	1.4	1.0	2.1	1.5	3.4	1.8
Over 1250 to and including 1700	0.8	1.4	1.0	2.1	1.5	3.4	2.2
Over 1700 to and including 2000			1.0	2.1	1.8	3.6	2.5
Over 2000 to and including 2360			1.2	2.4	1.8	3.6	3.0
Over 2360 to and including 2650			1.2	2.4	1.8	3.6	3.2
Over 2650 to and including 3000			1.2	2.4	1.8	3.6	3.5
Over 3000 to and including 3550			1.2	2.4	2.0	4.0	4.0
Over 3550 to and including 3750					2.0	4.0	4.5
Over 3750 to and including 5000					2.0	4.0	5.5

13. Tension

Belt Life Expectancy vs. Tension

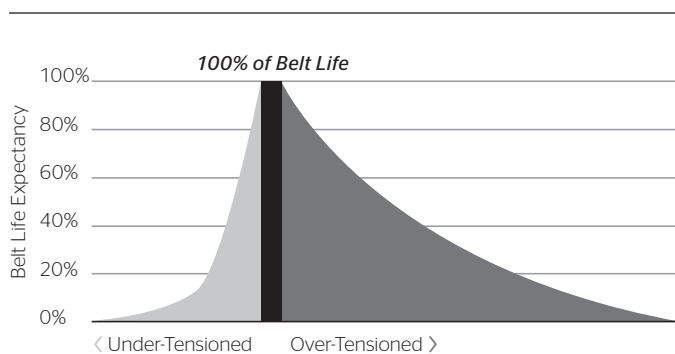

Belt Tension

- Optimal Belt Tension
- Under-Tensioned
- Over-Tensioned

Proper tension is essential for maximum belt life and efficiency.

Improper belt tension is the primary cause of premature belt failure and increased costs. Under-tensioned belts lead to slippage, overheating, rollover and noise, all of which lead to higher maintenance costs and inefficient transmission of power. Also, over-tensioning belts leads to premature wear, along with bearing, shaft and sheave problems. The result is more frequent replacement of drive components and costly downtime.

Common sense rules of V-belt tensioning

The ideal tension is the lowest tension at which the belt will not slip under peak load conditions.

Check the belt tension frequently during the first 24-48 hours of run-in operation.

Do not over-tension belts. Doing so will shorten belt and bearing life.

Keep belts free from foreign materials that may cause slippage. Inspect the V-drive periodically. Re-tension the belts if they are slipping.

Maintain sheave alignment with a strong straight-edge tool while tensioning V-belts.

Tensioning Methods

When you install belts at optimal tension, you save time and money. To illustrate this point, this table compares the cost and accuracy of various V-belt tensioning methods.

Average % Accuracy and Cost of Tensioning Devices

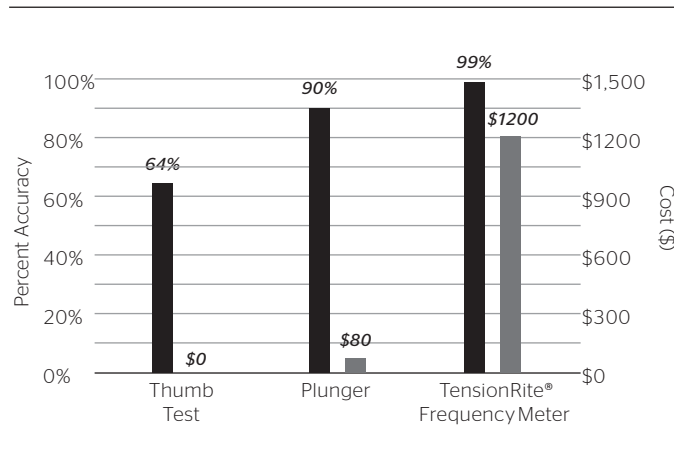

Comparison of V-Belt Tensioning Methods

Percent Accuracy
 Cost (\$)

Choose one of two tensioning methods for V-belts:

TensionRite® Belt Frequency Meter

Using advanced optical technology, our TensionRite® Belt Frequency Meter provides a simple, repeatable and reliable method for tensioning belts. It displays the natural vibration frequency of the belt strand so you can closely monitor belt tension. The device works with all industrial transmission belts, including V-belts, synchronous belts, banded belts and Poly-V® belts and calculates the corresponding belt tension in either English or SI units.



Deflection Principle

Plunger-type gauges utilize the deflection principle to check the tension of a belt drive.



The gauge deflects the center of the belt span and the force of this deflection is compared to a target deflection force for the particular span. Then, one can adjust the belt tension until the actual deflection force equals the target.

V-Belts Installation Guide

Measuring the Span Length

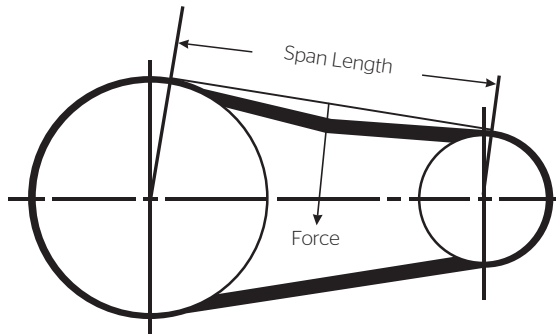

Deflection 1/64 in. per in. of span

Mark the center of the span. At the center mark, use a tension tester and apply a force perpendicular to the span large enough to deflect the belt 1/64 inch for every inch of span length (example: a 100 inch span requires a deflection of 100/64 inch or 1⁵/₁₆ inches).

Compare the actual deflection force with the values in Tables 5, 6 and 7 (at right and page 14). A force below the target value indicates under-tension. A force above the target indicates over-tension.

Table 5 Belt Deflection Force

		Belt Deflection (force pounds)				
		Uncogged HY-T® Belts and Uncogged HY-T® Torque Team®		Cogged Torque-Flex® and Machined Edge Torque Team® Belts		
Cross Section	Smallest Sheave Diameter Range	RPM Range	New Belt	Used Belt	New Belt	Used Belt
A, AX	3.0-3.6	1000-2500	5.5	3.7	6.1	4.1
		2501-4000	4.2	2.8	5.0	3.4
	3.8-4.8	1000-2500	6.8	4.5	7.4	5.0
		2501-4000	5.7	3.8	6.4	4.3
5.0-7.0	1000-2500	8.0	5.4	9.4	5.7	
	2501-4000	7.0	4.7	7.6	5.1	
B, BX	3.4-4.2	860-2500			7.2	4.9
		2501-4000			6.2	4.2
	4.4-5.6	860-2500	7.9	5.3	10.5	7.1
		2501-4000	6.7	4.5	9.1	6.2
5.8-8.6	860-2500	9.4	6.3	12.6	8.5	
	2501-4000	8.2	5.5	10.9	7.3	
C, CX	7.0-9.0	500-1740	17.0	11.5	21.8	14.7
		1741-3000	13.8	9.4	17.5	11.9
	9.5-16.0	500-1740	21.0	14.1	23.5	15.9
		1741-3000	18.5	12.5	21.6	14.6
D	12.0-16.0	200-850	37.0	24.9		
		851-1500	31.3	21.2		
	18.0-20.0	200-850	45.2	30.4		
		851-1500	38.0	25.6		

Table 6 Belt Deflection Force

Belt Deflection (force pounds)						
Cross Section	Smallest Sheave Diameter Range	RPM Range	Uncogged HY-T® Wedge Belts and Uncogged HY-T® Wedge Torque Team®		Cogged HY-T® Wedge Belts and HY-T® Wedge Machine Edge Torque Team®	
			New Belt	Used Belt	New Belt	Used Belt
3V, 3VX	2.2-2.4	1000-2500			4.9	3.3
		2501-4000			4.3	2.9
	2.65-3.65	1000-2500	5.1	3.6	6.2	4.2
		2501-4000	4.4	3.0	5.6	3.8
	4.12-6.90	1000-2500	7.3	4.9	7.9	5.3
		2501-4000	6.6	4.4	7.3	4.9
5V, 5VX	4.4-6.7	500-1749			15.2	10.2
		1750-3000			13.2	8.8
	3001-4000				8.5	5.6
		500-1740	18.9	12.7	22.1	14.8
	7.1-10.9	1741-3000	16.7	11.2	20.1	13.7
		11.8-16.0	500-1740	23.4	15.5	25.5
12.5-17.0	1741-3000		21.8	14.6	25.0	16.8
	8V	200-850	200-850	49.3	33.0	
851-1500			39.9	26.8		
200-850		200-850	59.2	39.6		
		851-1500	52.7	35.3		

Table 7 Belt Deflection Force

Cross Section	Smallest Sheave Diameter Range	RPM Range	Belt Deflection (force pounds)	
			New Belt	Used Belt
3VT	2.65-3.65	1000-2500	4.6	5.4
		2501-4000	4.0	4.7
	4.12-6.9	1000-2500	6.3	7.6
		2501-4000	5.8	6.9
5VT	7.1-10.9	500-1740	18.5	22.1
		1741-3000	16.4	19.6
	11.8-16	500-1740	21.6	25.8
		1741-3000	19.4	23.2
8VT	12.5-17.0	200-850	43.1	51.6
		851-1500	35.3	42.2
	18.0-22.4	200-850	51.3	61.4
		851-1500	46.1	55.2

V-Belts Installation Guide

The following sections detail other issues that could arise during V-belt drive installation:

14. Belt guards

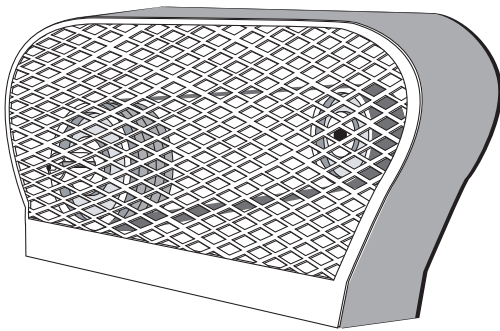

V-belt drive guards ensure cleanliness and safety. Screened, meshed or grilled guards are preferable because they allow for air circulation and heat escape.

15. Idlers

Avoid the use of idlers if at all possible. A properly-designed V-belt drive will not require an idler to deliver fully-rated horsepower. Idlers put an additional bending stress point on belts, which reduces their horsepower rating and life. Also, remember the smaller the idler, the greater the stress and the shorter a belt's life; however, if the drive design requires an idler, observe the following design recommendations.

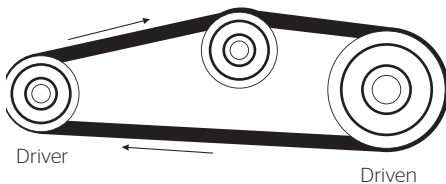

Inside idler

A V-grooved idler located on the inside of the belts on the slack side of the drive is preferable to a back side idler. Locate the idler near the large sheave to avoid reduction of the arc of contact with the small sheave.

Note that the size of the V-idler pulley should be equal to or larger (preferably) than the diameter of the small sheave.

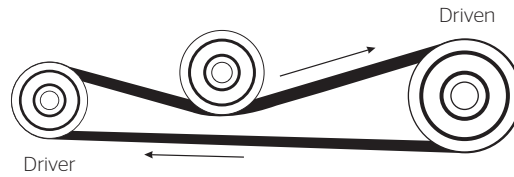

Back side idler

A back side idler increases the arc of contact on both sheaves; however, such an idler also forces a backward bend in the V-belt, which contributes to unwanted wear such as bottom cracking and premature failure. If a back side idler is the only option, follow two guidelines:

1. Make sure the diameter of the flat idler pulley is at least 1.5 times the diameter of the small sheave.

and

2. Locate the back side idler as close as possible to the small sheave on the slack side.

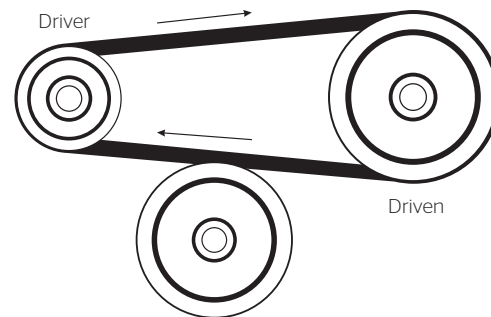

Kiss idler

Unlike the back side idler, the kiss idler does not penetrate the belt span and create a back bend. Consequently, the kiss idler does not contribute to premature failure. The kiss idler can help control belt vibration and whip on drives subject to shock and pulsating loads. When using a kiss idler, make sure the diameter of the flat pulley is at least 1.5 times the diameter of the small sheave on the slack side.

Torque Team® V-Belts Installation Guide

1. Inspect sheaves

The following sections outline installation procedures that will ensure maximum life and performance for your Torque Team® V-belts.

Check sheaves for cleanliness, damage and wear whether you are replacing an existing belt, performing routine maintenance or installing a new drive.

WARNING

Disconnect power supply to the machine before removing or installing sheaves or belts.

WARNING

Do not reinstall damaged or worn sheaves on equipment.

Sheave Groove Gauge

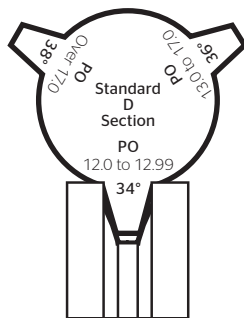

Use a stiff brush to remove rust and dirt. Use a soft cloth to wipe off oil and grease. Select the proper sheave groove gauge and template for the sheave diameter. Insert the gauge in the groove and look for voids that indicate dishing or other uneven and abnormal wear.

2. Install hardware

Always remember to select the correct sheave. Then, after you make the correct selection, be sure to install the sheaves correctly.

Before performing any installation, follow correct lockout procedures to prevent any accidents.

IMPORTANT: Disconnect power supply to machine **before doing ANY work.**

QD® Bushing (Conventional Mount)

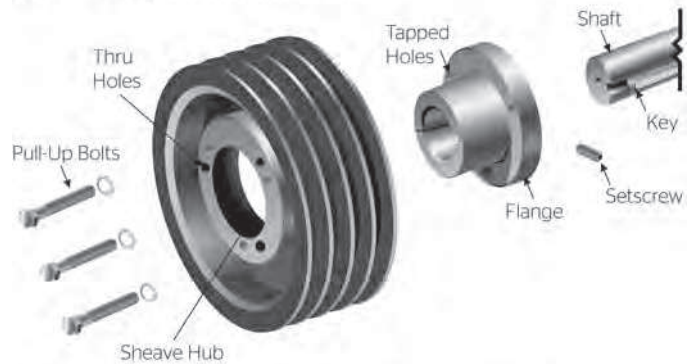

*QD® is a registered trademark of Emerson Power Transmission Manufacturing, L.P.

QD® Bushing

If the sheaves are made with a QD® hub, follow these installation and removal instructions:

3. How to install a sheave with a QD® hub

Insert the bushing in the hub and line up bolt holes.

Insert the pull-up bolts and turn until finger tight.

Hold the loosely-assembled unit so the bushing flange points toward the shaft bearings. Reverse mounting the QD® bushing can be advantageous for some applications.

Slip the unit onto the shaft and align the hub in the desired position.

Tighten the setscrew in the flange only enough to hold the assembly in position.

Tighten each pull-up bolt alternately and evenly.

Recheck alignment and completely tighten the setscrew on the shaft.

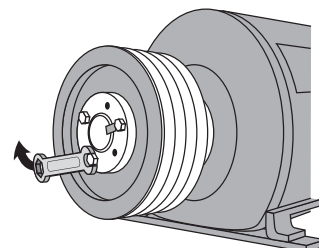

Torque Team® V-Belts Installation Guide

4. How to remove a sheave with a QD® hub

Place two of the pull-up bolts in the tapped holes in the sheave.

Turn the bolts alternately and evenly. They will push against the bushing flange and act as jackscrews to break the grip between the bushing and the tub.

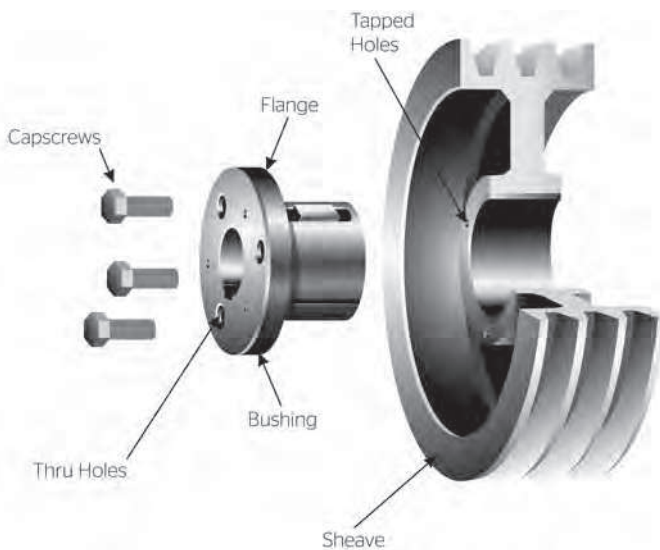

6. How to remove split taper bushing sheaves

Remove all capscrews.

Put two of the capscrews in the tapped holes in the flange of the bushing.

Turn the bolts alternately and evenly until the sheave has loosened.

Remove the sheave/flange assembly from the shaft.

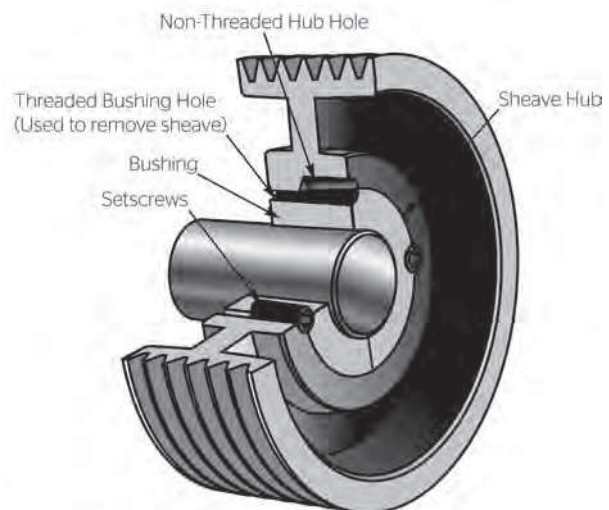

*Taper-Lock: TM Reliance Electric Company

Split Taper Bushing

If the sheaves are made for split taper bushings, follow these installation and removal instructions:

5. How to install split taper bushing sheaves

Put the bushing loosely in the sheave and start the capscrews.

Place the assembly on the shaft. Align both edges of the sheave with the edges of its mating sheave (example: the sheave on the driven shaft).

Tighten the capscrews according to the instructions furnished with the bushings.

Taper-Lock Bushing

7. How to install a sheave made with a taper-lock hub

Look at the bushing and the hub. Each has a set of half-holes.

The threaded holes in the hub are the mates to the non-threaded holes in the bushing.

Insert the bushing in the hub and slide it onto the shaft. Align a threaded hub hole with non-threaded bushing hole.

Start the setscrews into the holes that are threaded in the hub only. Do not tighten the setscrews yet.

Align both edges of the sheave with the edges of its mating sheave.

Tighten the screws alternately and evenly. This procedure will wedge the bushing inward and cause it to contract evenly and grip the shaft.

8. How to remove a sheave made with a taper-lock hub

Remove all the setscrews.

Place two of the setscrews in the holes that are threaded in the bushing only.

Turn the setscrews alternately and evenly. This movement will unlock the grip and permit easy removal of the assembly with no shock to the bearings or machinery.

9. Check alignment

Proper alignment is essential for long Torque Team® V-belt life. Check belt alignment whenever you maintain or replace belts or whenever you remove or install sheaves. Limit misalignment to 1/2 degree or approximately 1/10 inch per foot of center distance.

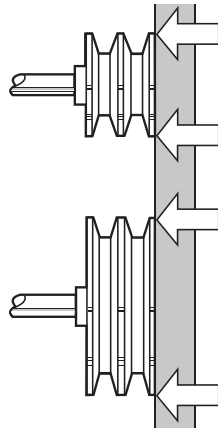

The illustration above shows the correct way to check alignment between two sheaves with a straight edge. Check both front and back alignment. Straight edge should touch sheaves at the four points indicated.

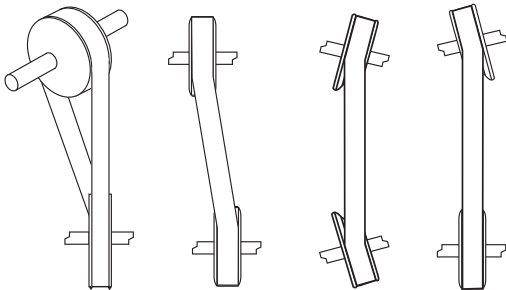

Non-parallel shafts or sheaves not aligned axially can cause angular misalignment.

Laser Alignment Tool

With our Laser Alignment Tool, you can quickly align drive components to improve efficiency and reduce costly maintenance. Much easier to use than a straight edge, it attaches in seconds and when the highly-visible sight line lies within the target openings, the pulley/sprockets are aligned.

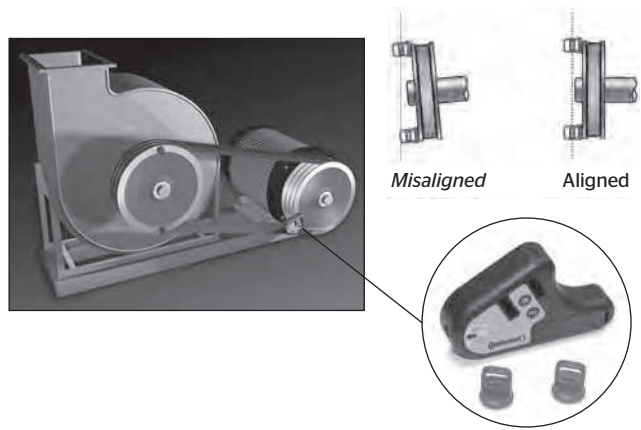

10. Identify correct belt

Always select belts to match sheave grooves. Use a sheave groove gauge to determine the proper belt cross section (Figure A). Make sure that the space between the grooves in the sheaves matches the spacing between belt ribs. Do not use Torque Team® belts in deep groove sheaves; such sheaves could cut through the backing that holds the ribs together.

Use a belt gauge to verify the old belt cross section when belt identification is no longer legible (Figure B).

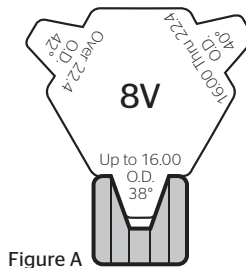

Figure A

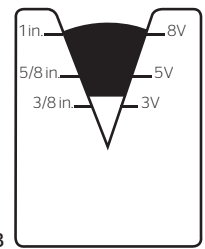

Figure B

Torque Team® V-Belts Installation Guide

11. Matching belts

Banded Torque Team® V-belts eliminate belt whip and turnover problems experienced with multiple V-belt sets under certain drive conditions. The individual ribs in the Torque Team® belts are produced at the same time and bonded together. Thus, ordering matched sets of individual V-belts is unnecessary.

Using more than one set of Torque Team® belts on the same drive is possible. For example, 2/5V1250 and 3/5V1250 Torque Team® belts will transmit the same power as five individual 5V1250 V-belts. The 2/5V1250 identification describes a Torque Team® belt with two 5V1250 individual V-belts joined together.

DO NOT mix belt brands.

DO NOT use sets from different manufacturers together as they may have different performance characteristics.

DO NOT use new and used Torque Team® belts in combined sets.

DO NOT use Torque Team Plus® belts in combined sets unless they are matched by the factory.

12. How to install Torque Team® belts

Never force Torque Team® belts into a sheave. Instead, decrease the center distance between the sheaves, allowing the belt to slip easily into the sheave grooves.

To tension a newly-installed Torque Team® belt, increase the center distance between the sheaves. Tables 8 and 9 (below and page 20) detail center distance allowances for installation and tensioning of Classical and HY-T® Wedge Torque Team® belts. For example, a 5/5V1250 Torque Team® belt requires decreasing the center distance 2.1 inches to install the belt and increasing the center distance 1.8 inches to maintain sufficient tension.

Shorter Center Distance for V-Belt Installation

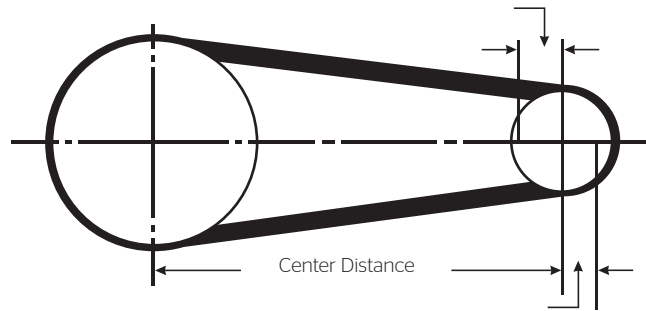

Longer Center Distance for V-Belt Take-Up

Table 8 HY-T® Plus V-Belts

Standard Length Designation	Minimum Allowance Below Standard Center Distance for Installation of Belts (in.)								Minimum Allowance Above Standard Center Distance for Maintaining Tension All Cross Sections
	A	B	B Torque Team® C	C Torque Team® D	D Torque Team® E				
Up to and including 35	0.75	1.00	1.50						1.00
Over 35 to and including 55	0.75	1.00	1.50	1.50	2.00				1.50
Over 55 to and including 85	0.75	1.25	1.60	1.50	2.00				2.00
Over 85 to and including 112	1.00	1.25	1.60	1.50	2.00				2.50
Over 112 to and including 144	1.00	1.25	1.80	1.50	2.10	2.00	2.90		3.00
Over 144 to and including 180		1.25	1.80	2.00	2.20	2.00	3.00	2.50	3.50
Over 180 to and including 210		1.50	1.90	2.00	2.30	2.00	3.20	2.50	4.00
Over 210 to and including 240		1.50	2.00	2.00	2.50	2.50	3.20	2.50	4.50
Over 240 to and including 300		1.50	2.20	2.00	2.50	2.50	3.50	3.00	5.00
Over 300 to and including 390				2.00	2.70	2.60	3.60	3.00	6.00
Over 390				2.50	2.90	3.00	4.10	3.50	1.5% of belt length

Table 9 HY-T® Wedge V-Belts

Standard Length Designation	Minimum Allowance Below Standard Center Distance for Installation of Belts (in.)						Minimum Allowance Above Standard Center Distance for Maintaining Tension All Cross Sections
	3V, 3VT	3V Torque Team®	5V, 5VT	5V Torque Team®	8V, 8VT	8V Torque Team®	
Up to and including 475	0.5	1.2					1.0
Over 475 to and including 710	0.8	1.4	1.0	2.1			1.2
Over 710 to and including 1060	0.8	1.4	1.0	2.1	1.5	3.4	1.5
Over 1060 to and including 1250	0.8	1.4	1.0	2.1	1.5	3.4	1.8
Over 1250 to and including 1700	0.8	1.4	1.0	2.1	1.5	3.4	2.2
Over 1700 to and including 2000			1.0	2.1	1.8	3.6	2.5
Over 2000 to and including 2360			1.2	2.4	1.8	3.6	3.0
Over 2360 to and including 2650			1.2	2.4	1.8	3.6	3.2
Over 2650 to and including 3000			1.2	2.4	1.8	3.6	3.5
Over 3000 to and including 3550			1.2	2.4	2.0	4.0	4.0
Over 3550 to and including 3750					2.0	4.0	4.5
Over 3750 to and including 5000					2.0	4.0	5.5

13. Tension

Belt Life Expectancy vs. Tension

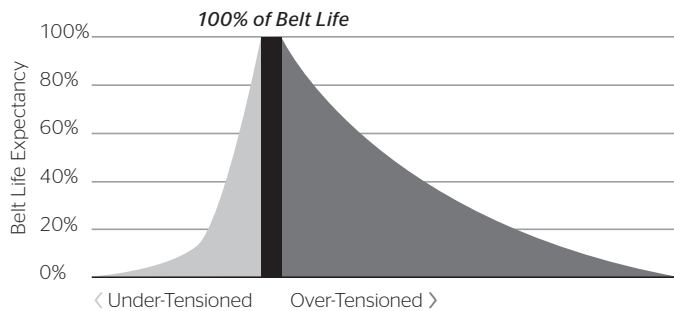

Belt Tension

- Optimal Belt Tension
- Under-Tensioned
- Over-Tensioned

Proper tension is essential for maximum belt life and efficiency. Improper belt tension is the primary cause of premature belt failure and increased costs. Under-tensioned belts lead to slippage, overheating, rollover and noise, all of which lead to higher maintenance costs and inefficient transmission of power.

Also, over-tensioning belts leads to premature wear, along with bearing, shaft and sheave problems. The result is more frequent replacement of drive components and costly downtime.

Common sense rules of V-belt tensioning

The ideal tension is the lowest tension at which the belt will not slip under peak load conditions.

Check the belt tension frequently during the first 24-48 hours of run-in operation.

Do not over-tension belts. Doing so will shorten belt and bearing life.

Keep belts free from foreign materials that may cause slippage. Inspect the V-drive periodically. Re-tension the belts if they are slipping.

Maintain sheave alignment with a strong straight-edge tool while tensioning V-belts.

Torque Team® V-Belts Installation Guide

Tensioning Methods

When you install belts at optimal tension, you save time and money. To illustrate this point, the figure below compares the cost and accuracy of various V-belt drive tensioning methods.

Average % Accuracy and Cost of Tensioning Devices

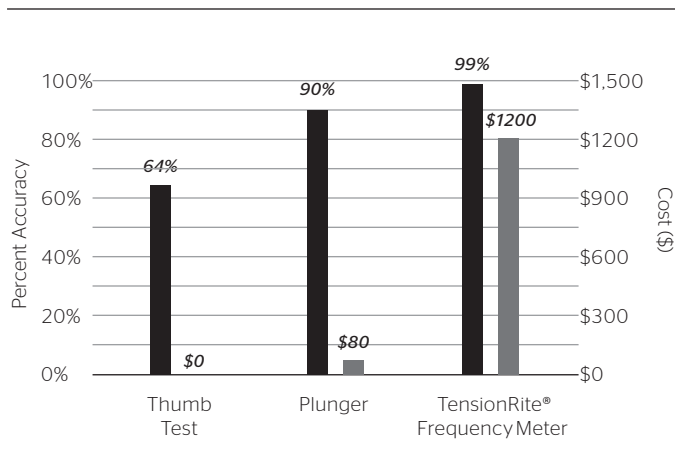

Comparison of V-Belt Tensioning Methods

- Percent Accuracy
- Cost (\$)

Choose one of two tensioning methods for V-belts:

TensionRite® Belt Frequency Meter

Using advanced optical technology, our TensionRite® Belt Frequency Meter provides a simple, repeatable and reliable method for tensioning belts. It displays the natural vibration frequency of the belt strand so you can closely monitor belt tension. The device works with all industrial transmission belts, including V-belts, synchronous belts, banded belts and Poly-V® belts and calculates the corresponding belt tension in either English or SI units.



Deflection Principle

Plunger-type gauges utilize the deflection principle to check the tension of a belt drive.



The gauge deflects the center of the belt span and the force of this deflection is compared to a target deflection force for the particular span. Then, one can adjust the belt tension until the actual deflection force equals the target.

Measuring the Span Length

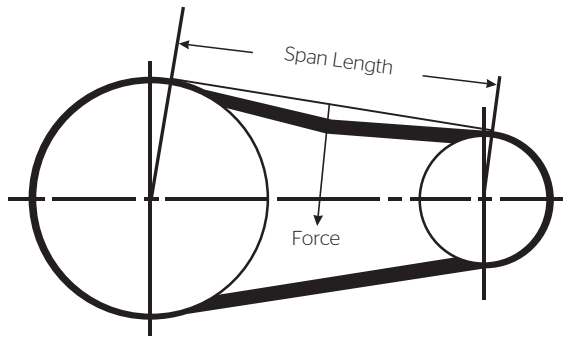

Deflection 1/64 in. per in. of span

Mark the center of the span. At the center mark, use a tension tester and apply a force perpendicular to the span large enough to deflect the belt 1/64 inch for every inch of span length (example: a 100 inch span requires a deflection of 100/64 inch or 1 5/16 inches).

Compare the actual deflection force with the values in Tables 10 and 11 (at right and page 23).

A force below the target value indicates under-tension. A force above the target indicates over-tension.

Table 10 Belt Deflection Force

		Belt Deflection (force pounds)			
		Uncogged HY-T® Belts and Uncogged HY-T® Torque Team®		Cogged Torque-Flex® and Machined Edge Torque Team® Belts	
Smallest Sheave Diameter Range	RPM Range	Used Belt	New Belt	Used Belt	New Belt
A, AX Cross Section					
3.0-3.6	1000-2500	3.7	5.5	4.1	6.1
	2501-4000	2.8	4.2	3.4	5.0
3.8-4.8	1000-2500	4.5	6.8	5.0	7.4
	2501-4000	3.8	5.7	4.3	6.4
5.0-7.0	1000-2500	5.4	8.0	5.7	9.4
	2501-4000	4.7	7.0	5.1	7.6
B, BX Cross Section					
3.4-4.2	860-2500			4.9	7.2
	2501-4000			4.2	6.2
4.4-5.6	860-2500	5.3	7.9	7.1	10.5
	2501-4000	4.5	6.7	6.2	9.1
5.8-8.6	860-2500	6.3	9.4	8.5	12.6
	2501-4000	5.5	8.2	7.3	10.9
C, CX Cross Section					
7.0-9.0	500-1740	11.5	17.0	14.7	21.8
	1741-3000	9.4	13.8	11.9	17.5
9.5-16.0	500-1740	14.1	21.0	15.9	23.5
	1741-3000	12.5	18.5	14.6	21.6
D Cross Section					
12.0-16.0	200-850	24.9	37.0		
	851-1500	21.2	31.3		
18.0-20.0	200-850	30.4	45.2		
	851-1500	25.6	38.0		

Torque Team® V-Belts Installation Guide

Table 11 Belt Deflection Force

		Belt Deflection (force pounds)			
		Uncogged HY-T® Wedge Belts and Uncogged HY-T® Wedge Torque Team®		Cogged HY-T® Wedge Belts and HY-T® Wedge Machine Edge Torque Team®	
Smallest Sheave Diameter Range	RPM Range	Used Belt	New Belt	Used Belt	New Belt
3V, 3VX Cross Section					
2.2-2.4	1000-2500			3.3	4.9
	2501-4000			2.9	4.3
2.65-3.65	1000-2500	3.6	5.1	4.2	6.2
	2501-4000	3.0	4.4	3.8	5.6
4.12-6.90	1000-2500	4.9	7.3	5.3	7.9
	2501-4000	4.4	6.6	4.9	7.3
5V, 5VX Cross Section					
4.4-6.7	500-1749			10.2	15.2
	1750-3000			8.8	13.2
	3001-4000			5.6	8.5
7.1-10.9	500-1740	12.7	18.9	14.8	22.1
	1741-3000	11.2	16.7	13.7	20.1
11.8-16.0	500-1740	15.5	23.4	17.1	25.5
	1741-3000	14.6	21.8	16.8	25.0
5VF Cross Section					
7.1-10.9	200-700	21.1	30.9		
	701-1250	18.0	26.3		
	1251-1900	16.7	23.4		
	1901-3000	15.8	23.0		
11.8-16.0	200-700	26.8	39.5		
	750-1250	23.5	34.7		
	1251-2100	22.7	33.3		
8V Cross Section					
12.5-17.0	200-850	33.0	49.3		
	851-1500	26.8	39.9		
18.0-22.4	200-850	39.6	59.2		
	851-1500	35.3	52.7		
8VF Cross Section					
12.5-20.0	200-500	44.7	65.8		
	501-850	38.5	56.6		
	851-1150	35.2	51.6		
	1151-1650	33.5	49.0		
21.2-25.0	200-500	65.9	97.6		
	501-850	61.2	90.6		
	851-1200	57.0	84.3		

Elongation Method

When the deflection force required for the Deflection Method becomes impractical for large Torque Team® belts, use the elongation method.

Imagine the Torque Team® belt as a very stiff spring, where a known amount of tension results in a known amount of elongation. The modulus of the Torque Team® belt is like the spring constant of a spring and is used to relate the elongation to the tension in the belt. The Elongation Method calculates the belt length associated with the required installation tension.

A gauge length is defined and used as a point of reference for measuring belt elongation. The gauge length could be the outside circumference of the belt or the span (or part of the span) length. The initial gauge length is measured with no belt tension.

The relationship between belt elongation and strand tension for one rib in a Torque Team® belt can be found by using the formula below, where the Modulus Factors are given in Table 12.

$$\text{Belt Length Multiplier} = 1 + \frac{\text{Strand Tension per Rib}}{\text{Modulus Factor}}$$

Table 12 Modulus Factors

Cross Section	3V, 3VX	5V, 5VX	5VF	8V	8VF	B, BX	C, CX	D
Modulus Factor (lb./in./in.)	14270	25622	160025	55548	260040	28547	43440	58882

Enter the required strand installation tension per rib into the formula, along with the Modulus Factor that corresponds to the cross section of the Torque Team® belt to determine the Belt Length Multiplier.

Multiply the gauge length by the Belt Length Multiplier to determine the final gauge length at the installation tension.

Example:

A 5/5V1250 belt is to be installed at 1400 lb. The Modulus Factor is 25622 lb./in./in. from Table 11.

The installation force is divided by the number of ribs in the Torque Team® (1400/5 = 280 lb.). The Belt Length Multiplier is calculated next.

$$\text{Belt Length Multiplier} = 1 + 280/25622 = 1.0109$$

Outside belt circumference at installation tension = $1.0109 \times 125 = 126.4$ inches.

In other words, the belt is elongated 1.4 inches at installation tension.

These multipliers do not apply to Torque Team Plus® belts.

The following few sections detail other issues that could arise during Torque Team® V-belt drive installation:

14. Belt guards

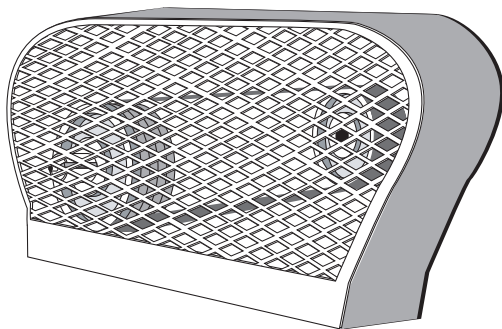

V-belt drive guards ensure cleanliness and safety. Screened, meshed or grilled guards are preferable because they allow for air circulation and heat escape.

15. Idlers

Avoid the use of idlers if at all possible. A properly designed Torque Team® V-belt drive will not require an idler to deliver fully-rated horsepower. Idlers put an additional bending stress point on belts, which reduces a belt's horsepower rating and its life. Also, remember the smaller the idler, the greater the stress and the shorter a belt's life; however, if the drive design requires an idler, observe the following design recommendations.

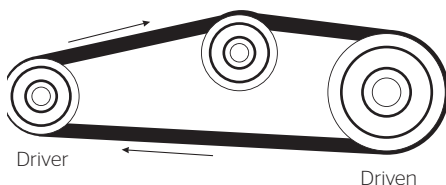

Inside idler

A V-grooved idler located on the inside of the belts on the slack side of the drive is preferable to a back side idler. Locate the idler near the large sheave to avoid reduction of the arc of contact with the small sheave.

Note that the size of the V-idler pulley should be equal to or larger (preferably) than the diameter of the small sheave.

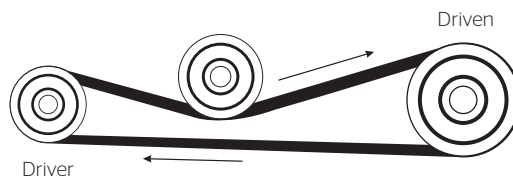

Back side idler

A back side idler increases the arc of contact on both sheaves; however, such an idler also forces a backward bend in the V-belt, which contributes to unwanted wear such as bottom cracking and premature failure. If a back side idler is the only option, follow two guidelines:

1. Make sure the diameter of the flat idler pulley is at least 1.5 times the diameter of the small sheave.
- and**
2. Locate the back side idler as close as possible to the small sheave on the slack side.

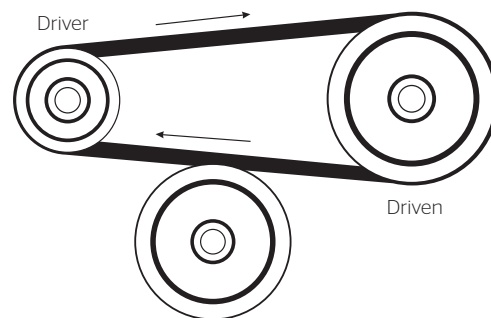

Kiss idler

Unlike the back side idler, the kiss idler does not penetrate the belt span and create a back bend. Consequently, the kiss idler does not contribute to premature failure. The kiss idler can help control belt vibration and whip on drives subject to shock and pulsating loads. When using a kiss idler, make sure the diameter of the flat pulley is at least 1.5 times the diameter of the small sheave on the slack side.

Poly-V® Belts

Installation Guide

1. Inspect sheaves

The following sections outline installation procedures that will ensure maximum life and performance for your Poly-V® belts.

Check sheaves for cleanliness, damage and wear whether you are replacing an existing belt, performing routine maintenance or installing a new drive.

WARNING

Disconnect power supply to the machine before removing or installing sheaves or belts.

WARNING

Do not reinstall damaged or worn sheaves on equipment.

Minimum sheave diameter

If the sheave driver is a standard electric motor, refer to Table 13 to be sure that the sheave diameter selected will meet the National Electrical Manufacturers Association Standard for minimum sheave diameters for electric motors. If the motor sheave is smaller than the minimum diameter shown in this table, increase the sheave diameter so that the motor sheave will conform with the chart unless either an oversize or outboard bearing is installed.

Perform further inspection if possible. Use Table 14 (on page 26) to determine if excessive wear has occurred or to select replacement belts and sprocket cross sections.

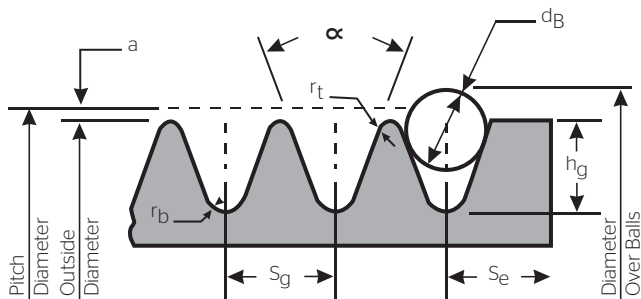

Table 13 Small Sheave Diameters for Electric Motors

For example, if you are installing a 220J8, the minimum allowance below center distance is 1/2 in. If you are working to maintain tension, the minimum allowance above center distance for belt take-up is also 1/2 in.

Motor Nameplate Horsepower	Standard Motor RPM					
	3450	1750	1160	870	675	575
	Small Sheave Diameters (in.)					
.12 or less	1.25	1.50	1.50			
.25	1.25	1.25	1.50			
.33	1.50	1.50	2.00			
.50	2.00	2.00	2.50			
.75	2.25	2.25	2.50	3.00	3.00	3.00
1	2.25	2.25	2.50	3.00	3.00	3.00
1.5	2.25	2.50	2.50	3.00	3.00	3.00
2	2.50	2.50	2.50	3.00	3.00	3.75
3	2.50	2.50	3.00	3.00	3.75	4.50
5	2.50	3.00	3.00	3.75	4.50	4.50
7.5	3.00	3.00	3.75	4.50	4.50	5.25
10	3.00	3.75	4.50	4.50	5.25	6.00
15	3.75	4.50	4.50	5.25	6.00	6.75
20	4.50	4.50	5.25	6.00	6.75	8.25
25	4.50	4.50	6.00	6.75	8.25	9.00
30		5.25	6.75	6.75	9.00	10.00
40		6.00	6.75	8.25	10.00	10.00
50		7.00	8.38	9.00	10.00	11.00
60		7.63	9.00	10.00	11.00	12.00
75		9.00	10.00	10.00	13.00	14.00
100		10.00	13.00	13.00	15.00	18.00
125		11.00	13.00	15.00	18.00	20.00
150			13.00	18.00	20.00	22.00
200				22.00	22.00	22.00
250					22.00	22.00
300					27.00	27.00

Table 14 Groove Dimensions

Groove Dimensions (in.)									
Cross Section	Minimum Recommended Outside Diameter (in.)	Angle Groove $\alpha \pm 0.50$ Degrees	S_g^*	$r_t +0.005 - 0.000$	a	r_b	h_g Minimum	$d_g \pm 0.0004$	S_e
H	0.50	40	0.063 ± 0.001	0.005	0.020	0.013 +0.000 -0.005	0.041	0.0469	0.080 +0.020 -0.010
J	0.80	40	0.092 ± 0.001	0.008	0.030	0.015 +0.000 -0.005	0.071	0.125 0.0625 -0.015	0.125 +0.030 -0.015
K	1.50	40	0.140 ± 0.002	0.010	0.038	0.020 +0.000 -0.005	0.122	0.125 0.1093 0.00	0.125 +0.050 0.000
L	3.00	40	0.185 ± 0.002	0.015	0.058	0.015 +0.000 -0.005	0.183	0.375 0.1406 -0.030	0.375 +0.075 -0.030
M	7.00	40	0.370 ± 0.002	0.030	0.116	0.030 +0.000 -0.010	0.377	0.500 0.2812 -0.040	0.500 +0.100 -0.040

Summation of the deviations from S_g^ for all grooves in any one sheave shall not exceed ± 0.010 in.

2. Installation

Before performing any installation, follow correct lockout procedures to prevent any accidents.

IMPORTANT: Disconnect power supply to machine **before** doing ANY work.

JD® Bushing (Conventional Mount)

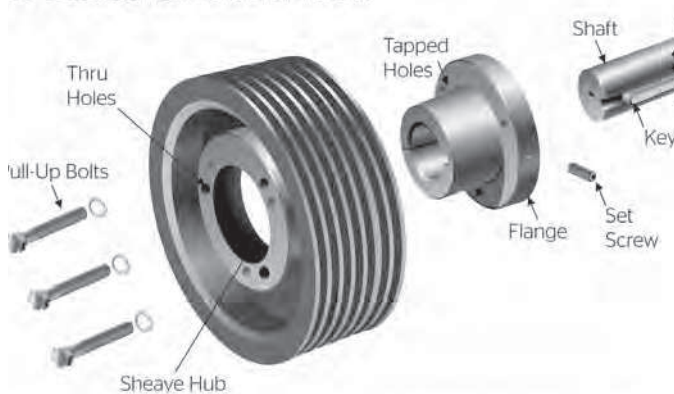

JD® is a registered trademark of Emerson Power Transmission Manufacturing, L.P.

Poly-V® Belts

Installation Guide

QD® Bushing

If the sheaves are made with a QD® hub, follow these installation and removal instructions:

3. How to install a sheave with a QD® hub

Insert the bushing in the hub and line up bolt holes.

Insert the pull-up bolts and turn until finger tight.

Hold the loosely-assembled unit so the bushing flange points toward the shaft bearings. Reverse mounting the QD® bushing can be advantageous for some applications.

Slip the unit onto the shaft and align the hub in the desired position.

Tighten the setscrew in the flange only enough to hold the assembly in position.

Tighten each pull-up bolt alternately and evenly.

Recheck alignment and completely tighten the setscrew on the shaft.

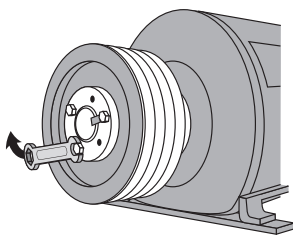

4. How to remove a sheave with a QD® hub

Place two of the pull-up bolts in the tapped holes in the sheave.

Turn the bolts alternately and evenly. They will push against the bushing flange and act as jackscrews to break the grip between the bushing and the tub.

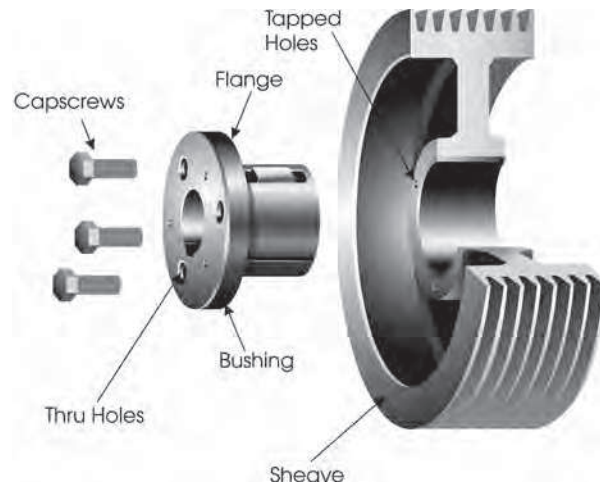

Split Taper Bushing

If the sheaves are made for split taper bushings, follow these installation and removal instructions:

5. How to install split taper bushing sheaves

Put the bushing loosely in the sheave and start the capscrews.

Place the assembly on the shaft. Align both edges of the sheave with the edges of its mating sheave (example: the sheave on the driven shaft).

Tighten the capscrews according to the instructions furnished with the bushings.

6. How to remove split taper bushing sheaves

Remove all capscrews.

Put two of the capscrews in the tapped holes in the flange of the bushing.

Turn the bolts alternately and evenly until the sheave has loosened.

Remove the sheave/flange assembly from the shaft.

Small Sheave Diameters for Electric Motors

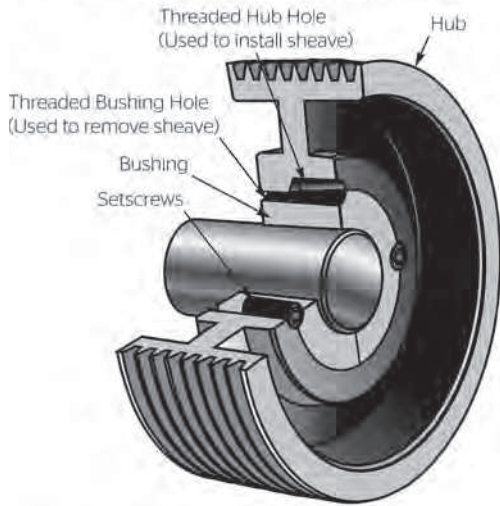

*Taper-Lock: TM Reliance Electric Company

Taper-Lock Bushing

7. How to install a sheave made with a taper-lock hub

Look at the bushing and the hub. Each has a set of half-holes.

The threaded holes in the hub are the mates to the non-threaded holes in the bushing.

Insert the bushing in the hub and slide it onto the shaft. Align a threaded hub hole with non-threaded bushing hole.

Start the setscrews into the holes that are threaded in the hub only. Do not tighten the setscrews yet.

Align both edges of the sheave with the edges of its mating sheave.

Tighten the screws alternately and evenly. This procedure will wedge the bushing inward and cause it to contract evenly and grip the shaft.

8. How to remove a sheave made with a taper-lock hub

Remove all the setscrews.

Place two of the setscrews in the holes that are threaded in the bushing only.

Turn the setscrews alternately and evenly. This movement will unlock the grip and permit easy removal of the assembly with no shock to the bearings or machinery.

9. Check alignment

Proper alignment is essential for long Poly-V® belt life. Check belt alignment whenever you maintain or replace belts or whenever you remove or install sheaves. Limit misalignment to 1/4 degree or approximately 1/16 inch per foot of center distance.

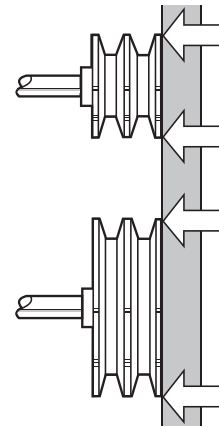

The illustration above shows the correct way to check alignment between two sheaves with a straight edge. Check both front and back alignment. Straight edge should touch sheaves at the four points indicated.

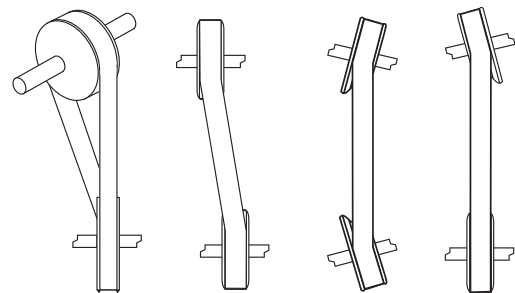

Non-parallel shafts or sheaves not aligned axially can cause angular misalignment.

Poly-V® Belts Installation Guide

Laser Alignment Tool

With our Laser Alignment Tool, you can quickly align drive components to improve efficiency and reduce costly maintenance. Much easier to use than a straight edge, it attaches in seconds. When the highly-visible sight line lies within the target openings, the pulley/sprockets are aligned.

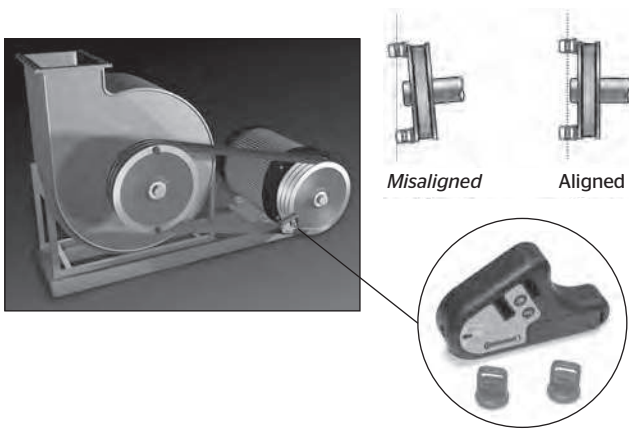

10. Identify correct belt

Always select belts to match sheave grooves.

Size Designation Belt

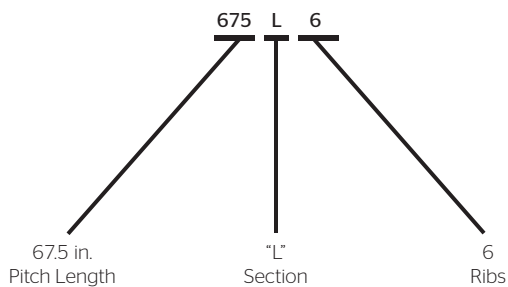

Pulley

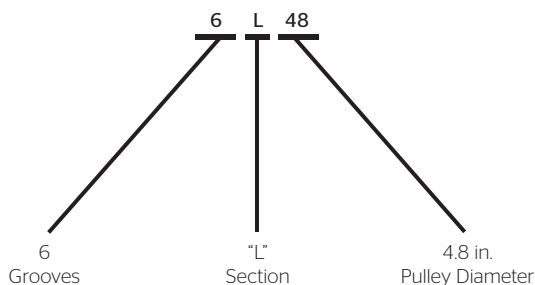

11. Matching belts

Matching multiple belts is not necessary for most Poly-V® belt drives. If you encounter a special application calling for matching, specify “matched belts” on the order.

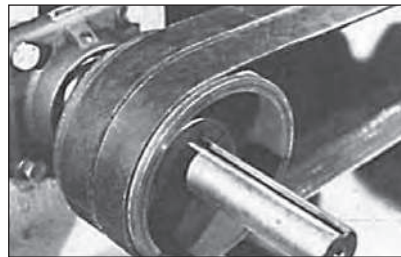

12. How to install belts

After you correctly install and align the sheaves, you can install the belts.

Always move the drive unit so you can easily slip the belts into the grooves without force.



Never force belts into a sheave with a tool such as a screwdriver or a wedge. Doing so may damage the ribs or break the cords.



Refer to Table 15 (on page 30) to determine if enough clearance exists for belt installation and take-up.

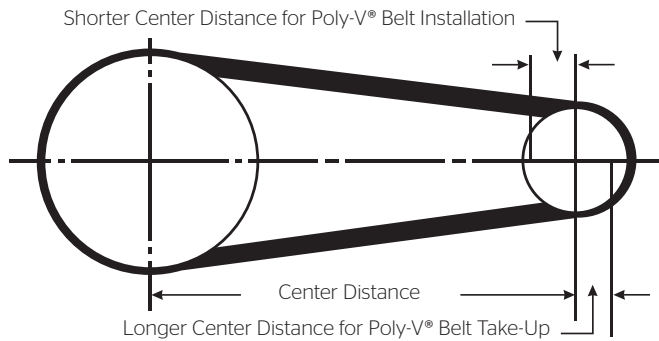

For example, if you are installing a 220J8, the minimum allowance below center distance is 1/2 inch. If you are working to maintain tension, the minimum allowance above center distance for belt take-up is also 1/2 inch.

Table 15 Poly-V® Belt Recommended Installation and Take-Up Allowances

Recommended Installation and Take-Up Allowances (in.)

Standard Effective Length	Minimum Allowance Below Standard Center Distance for Installation of Belts			Minimum Allowance Above Standard Center Distance for Maintaining Tension, All Cross Sections
	J	L	M	
Up to and including 20.0	0.4			0.3
Over 20.0 to and including 40.0	0.5			0.5
Over 40.0 to and including 60.0	0.6	0.9		0.7
Over 60.0 to and including 80.0	0.6	0.9		0.9
Over 80.0 to and including 100.0	0.7	1.0	1.5	1.1
Over 100.0 to and including 120.0	0.8	1.1	1.6	1.3
Over 120.0 to and including 160.0		1.2	1.7	1.7
Over 160.0 to and including 200.0		1.3	1.8	2.2
Over 200.0 to and including 240.0		1.4	1.9	2.6
Over 240.0 to and including 300.0			2.2	3.3
Over 300.0 to and including 360.0			2.3	3.9
Over 360.0 to and including 420.0			2.6	4.6
Over 420.0 to and including 480.0			2.9	5.2
Over 480.0 to and including 540.0			3.2	5.8
Over 540.0 to and including 600.0			3.6	6.5

13. Tension

Belt Life Expectancy vs. Tension

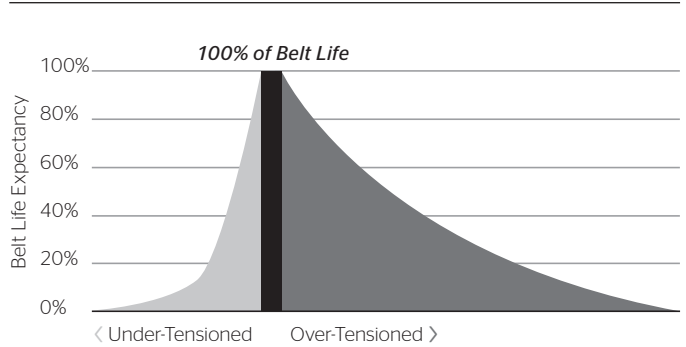

Belt Tension

- Optimal Belt Tension
- Under-Tensioned
- Over-Tensioned

Proper tension is essential for maximum belt life and efficiency. Improper belt tension is the primary cause of premature belt failure and increased costs. Under-tensioned belts lead to slippage, overheating and noise, all of which lead to higher maintenance costs and inefficient transmission of power. Also, over-tensioning belts leads to premature wear, along with bearing, shaft and pulley problems. The result is more frequent replacement of drive components and costly downtime.

Common sense rules of Poly-V® belt tensioning

The ideal tension is the lowest tension at which the belt will not slip under peak load conditions.

Check the belt tension frequently during the first 24-48 hours of run-in operation.

Do not over-tension belts. Doing so will shorten belt and bearing life.

Keep belts free from foreign materials that may cause slippage. Inspect the Poly-V® drive periodically. Re-tension the belts if they are slipping.

Maintain sheave alignment with a strong straight-edge tool while tensioning Poly-V® belts.

Poly-V® Belts Installation Guide

Tensioning Methods

Choose one of two tensioning methods for Poly-V® belts:

TensionRite® Belt Frequency Meter

Using advanced optical technology, our TensionRite® Belt Frequency Meter provides a simple, repeatable and reliable method for tensioning belts. It displays the natural vibration frequency of the belt strand so you can closely monitor belt tension. The device works with all industrial transmission belts, including V-belts, synchronous belts, banded belts and Poly-V® belts and calculates the corresponding belt tension in either English or SI units.



Deflection Principle

Plunger-type gauges utilize the Deflection Principle to check the tension of a belt drive.



The gauge deflects the center of the belt span and the force of this deflection is compared to a target deflection force for the

particular span. Then, one can adjust the belt tension until the actual deflection force equals the target.

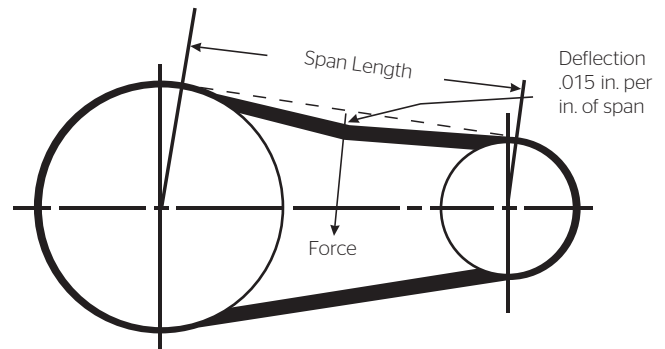

Run the drive briefly to properly seat the belt. At least one sheave should rotate freely during the tensioning procedure.

Measure the span length (see illustration).

Mark the center of span. At the center point, use a tension tester and apply a force perpendicular to the span large enough to deflect the belt 1/64 inch for every inch of span length (example: a 100 inch span requires a deflection of 100/64 inch or 1 5/8 inches).

Compare the actual deflection force with the values in Table 16 below.

A force below the target value indicates under-tension; a force above the target indicates over-tension.

Table 16 Belt Deflection Force

Belt Cross Section	Small Sheave Diameter Range	Force "F" (lb. per rib)
J	1.32-1.67	0.4
J	1.77-2.20	0.5
J	2.36-2.95	0.6
L	2.95-3.74	1.7
L	3.94-4.92	2.1
L	5.20-6.69	2.5
M	7.09-8.82	6.4
M	9.29-11.81	7.7
M	12.40-15.75	8.8

The following few sections detail other issues that could arise during a Poly-V® belt drive installation:

14. Belt guards

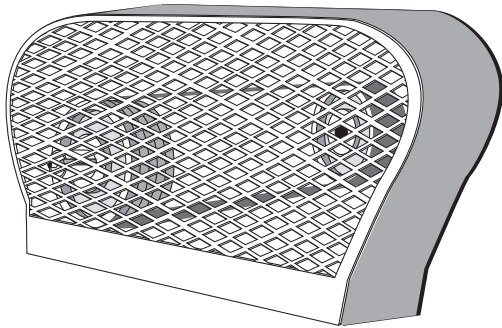

Poly-V® belt drive guards ensure cleanliness and safety. Screened, meshed or grided guards are preferable because they allow for air circulation and heat escape.

15. Idlers

Even though Poly-V® belts are designed to handle idlers better than most other power transmission belts, idlers will reduce belt life and should be avoided. Idlers put an additional bending stress point on the belts, which reduces the belt's horsepower rating and its life. The smaller the idler, the greater this stress and the shorter the belt's life. If the drive design requires an idler, observe the following design recommendations.

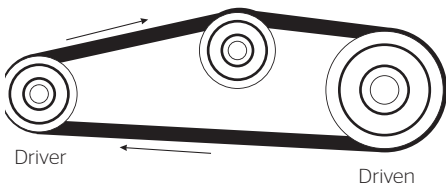

Inside idler

A V-grooved idler located on the inside of the belts on the slack side of the drive is preferable to a back side idler. Locate the idler near the large sheave to avoid reduction of the arc of contact with the small sheave.

Note that the size of the V-idler pulley should be equal to or larger (preferably) than the diameter of the small sheave.

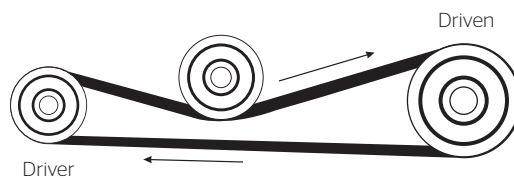

Back side idler

A back side idler increases the arc of contact on both sheaves; however, such an idler also forces a backward bend in the Poly-V® belt, which contributes to unwanted wear such as rib cracking and premature failure. If a back side idler is the only option, follow two guidelines:

1. Make sure the diameter of the flat idler pulley is at least 1.5 times the diameter of the small sheave.

and

2. Locate the back side idler as close as possible to the small sheave.

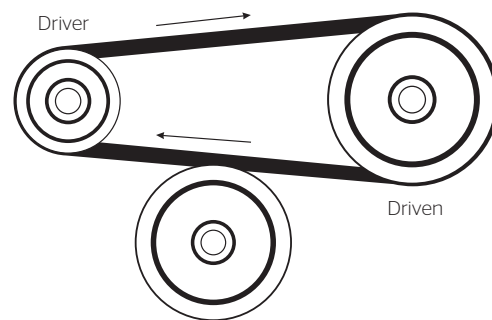

Kiss idler

Unlike the back side idler, the kiss idler does not penetrate the belt span and create a back bend. Consequently, the kiss idler does not contribute to premature failure. The kiss idler can help control belt vibration and whip on drives subject to shock and pulsating loads. When using a kiss idler, make sure the diameter of the flat pulley is at least 1.5 times the diameter of the small sheave.

Variable Speed Belts

Installation Guide

1. Inspect sheaves

The following sections outline installation procedures that will ensure maximum life and performance for your Variable Speed belts.

Check sheaves for cleanliness, damage and wear whether you are replacing an existing belt, performing routine maintenance or installing a new drive.

WARNING

Disconnect power supply to the machine before removing or installing sheaves or belts.

WARNING

Do not reinstall damaged or worn sheaves on equipment.

Worn sidewalls also interfere with the shifting action. Nicks or gouges can cut the belt. Dirt on the belt and in the grooves can abrade the belt and oil can attack the belt materials. Use a stiff brush to clean off rust and dirt. Wipe off any oil and grease. Worn moving parts cause vibration and reduce belt life.

Types of Variable Speed Drives

Variable to Fixed Sheave

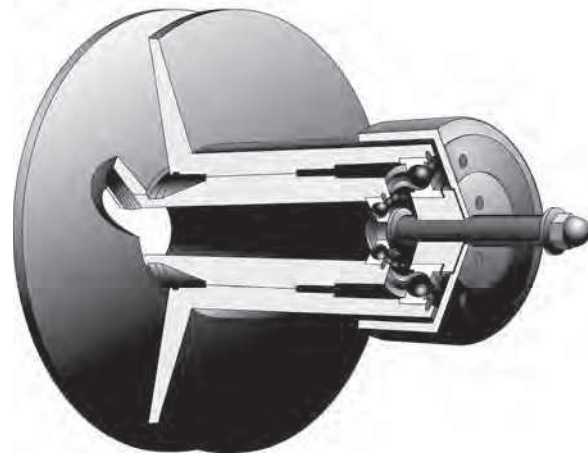

Both Sheaves Variable

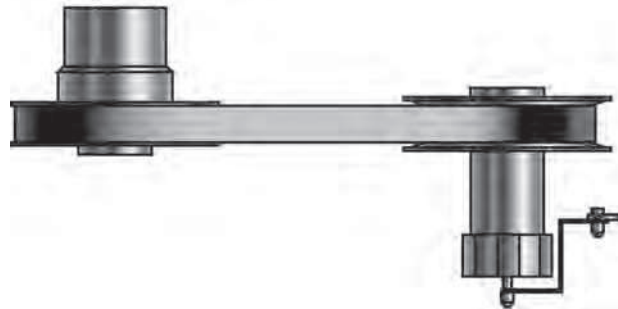

2. Check alignment

Proper alignment is more critical for variable speed drive sheaves than for conventional V-belt drives. Check belt alignment whenever you maintain or replace belts or remove or install sheaves.

This illustration (Figure A), shows the correct way to check alignment between two variable speed drive sheaves.

Another illustration (Figure B), shows a belt misaligned. To correct the alignment, move one sheave so that the straight edge is equidistant from both sides of the narrow sheave. The belt edges should also be equidistant from the straight edge.

Figure A: Properly Aligned

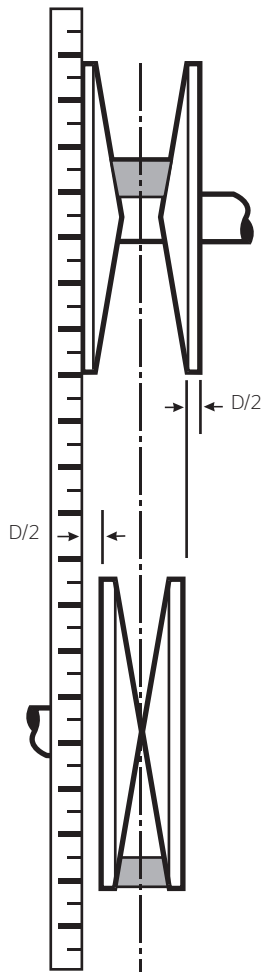

RIGHT
The belt is parallel to the straight edge

Figure B: *Misaligned*

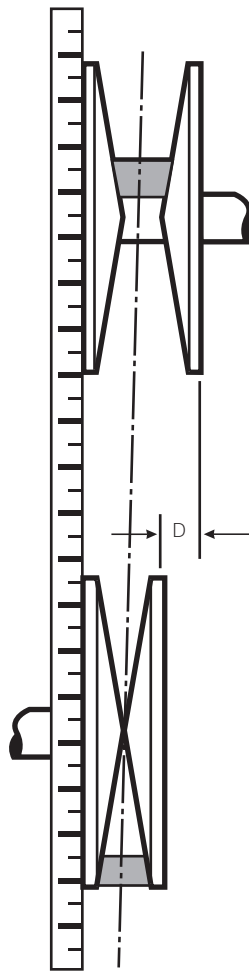

WRONG
Check for misalignment and offset distance "D"

3. Identify correct belt

To select the correct belt, refer to the drive manufacturer's recommendations. The belt length is most critical on fixed center drives with both pulleys variable since accurate length is required to achieve precise drive speed variations. Belt length with one variable and one fixed pulley is also critical as it affects the allowable increase and decrease in center distances.

4. How to install belt

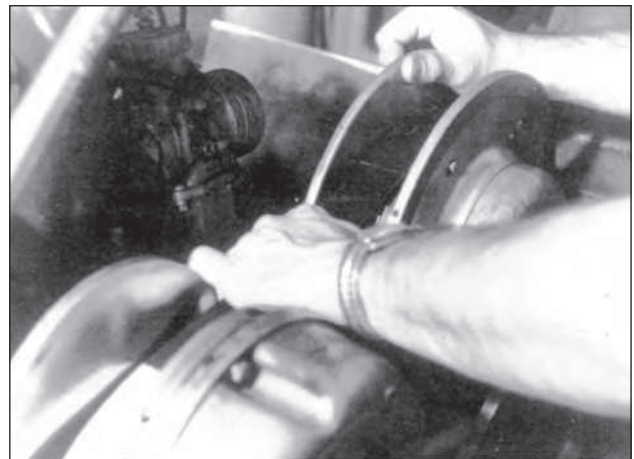

Take special care during the installation of variable speed belts to avoid damage to the belts and sheaves. You may have to open variator sheaves fully to facilitate installation. You may also have to shorten the drive center distance to allow for easy installation. Also, you may have to remove sheaves. After assembly, return the drive center distance to normal and recheck drive alignment.

5. Tension

Spring loaded sheaves, which apply the tension required to handle the design load, govern variable speed belt tensioning.

6. Belt guards

Belt guards ensure cleanliness and safety. Screened, meshed or grilled guards are preferable because they allow for air circulation and heat escape. Note: refer to www.osha.org.

7. Idlers

Idlers are not recommended for variable speed drives.

Synchronous Belts

Installation Guide

1. Inspect sprockets

The following sections outline installation procedures that will ensure maximum life and performance for your Continental ContiTech synchronous belts such as Hawk Pd®, Blackhawk Pd®, Falcon Pd® and SilentSync® belts.

WARNING

Disconnect power supply to the machine before removing or installing sheaves or belts.

WARNING

Do not reinstall damaged or worn sheaves on equipment.

Worn teeth will cause belt wear and/or damage. Nicks or gouges can cut the belt. Dirt on the teeth and in the grooves can abrade the belt and oil can attack belt materials.

Use a stiff brush to remove rust and dirt. Use a soft cloth to wipe off oil and grease.

Make sure the components are ready for installation. Clean all shafts, removing any nicks or burrs. Clean all mating surfaces of the sprocket, bushing and shaft. Do not use lubrication or anti-seize solution on any of these surfaces.

Make sure the shafts are true and parallel by accurately measuring the distance between the shafts at three points along the shaft. The distance between the shafts should be the same at all three points as shown.

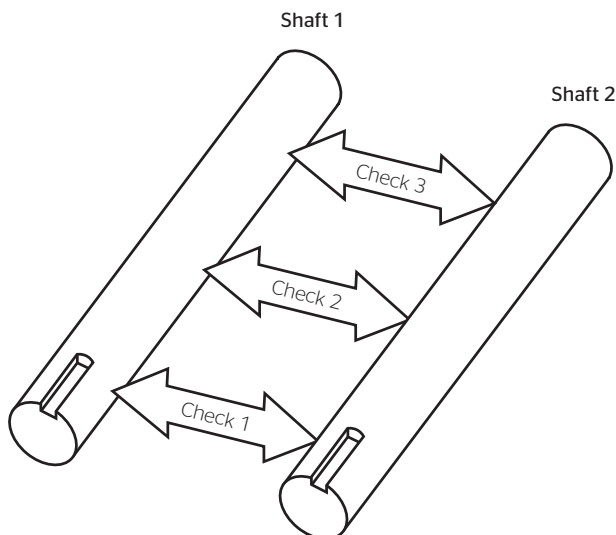

Also, make sure the shafts are rigidly mounted. Shafts should not deflect when the belt is tensioned.

2. Install hardware

Correct sprocket selection and installation is important. Before performing any installation, follow correct lockout procedures to prevent any accidents.

IMPORTANT: Disconnect power supply to machine **before** doing **ANY** work.

QD® Bushing (Conventional Mount)

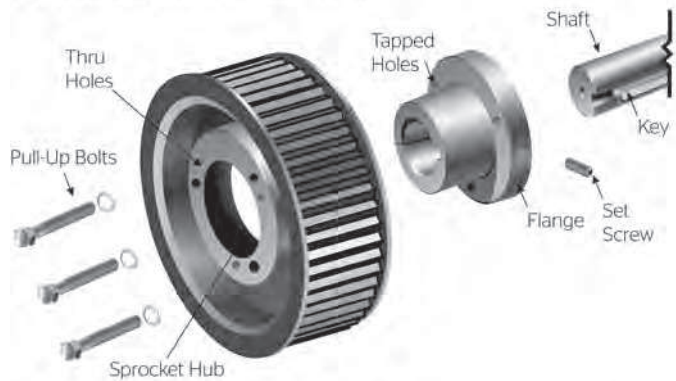

*QD® is a registered trademark of Emerson Power Transmission Manufacturing, L.P.

QD® Bushing

If the sheaves are made with a QD® hub, follow these installation and removal instructions:

3. How to install a sprocket with a QD® hub

For conventional mounting, insert bushing into the sprocket, aligning the tapped holes in the bushing flange with the thru holes in the sprocket hub.

Insert capscrews through the thru holes and into the tapped holes.

Insert the key into the keyseat of the shaft.

With capscrews to the outside, place the sprocket and bushing assembly on the shaft, positioning the assembly with the bushing flange towards the shaft bearings. Reverse mounting the QD® bushing can be advantageous for some applications.

Mount the other sprocket in a similar manner.

Check that the teeth of both sprockets are pointing in the same direction when installing SilentSync® sprockets.

Snug the capscrews so that the sprocket/bushing assembly can still move on the shaft.

Align the sprockets using a straight edge. Check for contact in four places as shown. Do not use bearings or drive shafts as reference points for sprocket alignment.

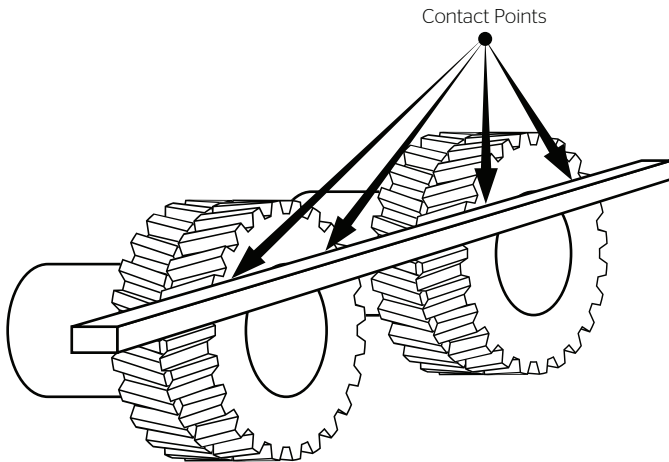

Using a torque wrench, tighten the capscrews to the torque values listed below. If there is not a gap of 1/8 inch to 1/4 inch between the bushing flange and the sprocket hub then disassemble the parts and determine the reason for the faulty assembly.

The sprocket will draw onto the bushing during tightening. Always recheck alignment after tightening the capscrews. If alignment has changed, loosen the capscrews and move sprocket/bushing assembly on shaft to realign. Tighten the setscrews over the keyway to the torque values listed in the table.

If the sprockets are straight bore, use the above alignment procedure and then tighten the setscrews to the correct torque for the setscrew size as listed in Table 17.

QD® bushings can be installed with the capscrews on either side, excluding QT, M and N sizes. Drives with opposing shafts require one of the sprockets to be mounted with the capscrew on the flange side and one with the capscrews on the hub side

Table 17 Torque Specifications

Bushing	Capscrew Torque		Setscrew Torque (in.-lb.)	Setscrew Size (in.)
	(in.-lb.)	(ft.-lb.)		
H	108	9		
SH	108	9	87	1/4
SDS	108	9	87	1/4
SK	180	15	87	1/4
SF	360	30	165	5/16
E	720	60	290	3/8
F	900	75	290	3/8
J	1620	135	290	3/8
M	2700	225	290	3/8
N	3600	300	620	1/2

4. How to remove a sprocket with a QD® hub

Place two of the pull-up bolts in the tapped holes in the sprocket.

Turn the bolts alternately and evenly. They will push against the bushing flange and act as jackscrews to break the grip between the bushing and the hub.

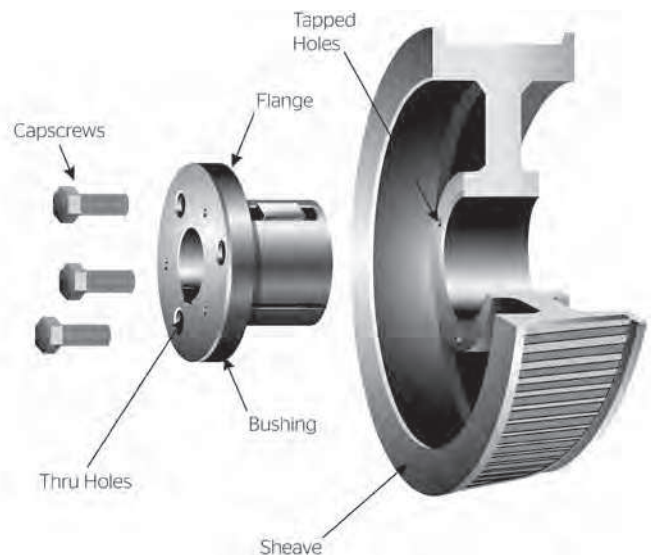

Synchronous Belts

Installation Guide

Split Taper Bushing

If the sprockets are made for split taper bushings, follow these installation and removal instructions:

5. How to install split taper bushing sprockets

Put the bushing loosely in the sprocket and start the capscrews.

Place the assembly on the shaft. Align both edges of the sprocket with the edges of its mating sprocket (example: the sprocket on the driven shaft).

Tighten the capscrews according to the instructions furnished with the bushings.

6. How to remove split taper bushing sprockets

Remove all capscrews.

Put two of the capscrews in the tapped holes in the flange of the bushing.

Turn the bolts alternately and evenly until the sprocket has loosened.

Remove the sprocket/bushing assembly from the shaft.

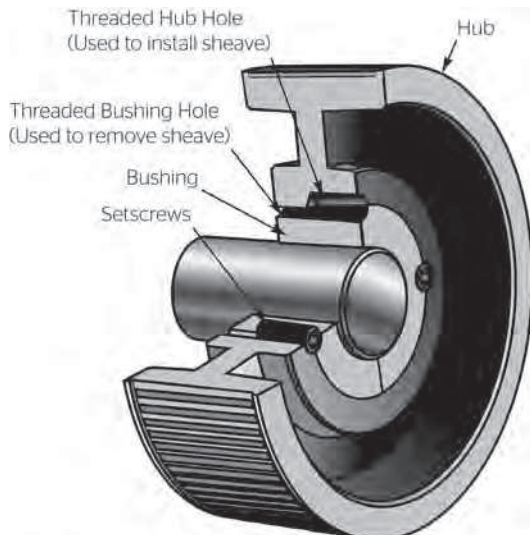

*Taper-Lock. TM Reliance Electric Company

Taper-Lock Bushing

The following instructions illustrate how to install a sprocket made with a taper-lock hub:

7. How to install a sprocket made with a taper-lock hub

Look at the bushing and the hub. Each has a set of half-holes.

The threaded holes in the hub are the mates to the non-threaded holes in the bushing.

Insert the bushing in the hub and slide it onto the shaft. Align a threaded hub hole with non-threaded bushing hole.

Start the setscrews into the holes that are threaded in the hub only. Do not tighten the setscrews yet.

Align both edges of the sprocket with the edges of its mating sprocket.

Tighten the screws alternately and evenly. This procedure will wedge the bushing inward and cause it to contract evenly and grip the shaft.

8. How to remove a sprocket made with a taper-lock hub

Remove all the setscrews.

Place two of the setscrews in the holes that are threaded in the bushing only.

Turn the setscrews alternately and evenly. This movement will unlock the grip and permit easy removal of the assembly with no shock to the bearings or machinery.

9. Check Alignment

Drive Alignment

Synchronous belts are very sensitive to misalignment. The tension carrying member has a high tensile strength and resistance to elongation, resulting in a very stable belt product. Any misalignment will lead to inconsistent belt wear, uneven load distribution and premature tensile failure. In general, synchronous drives should not be used where misalignment is a problem. Limit misalignment to 1/4 degree or approximately 1/16 inch per foot of center distance. With parallel shafts, misalignment occurs when there is an offset between the sprocket faces as in Figure A.

Figure A

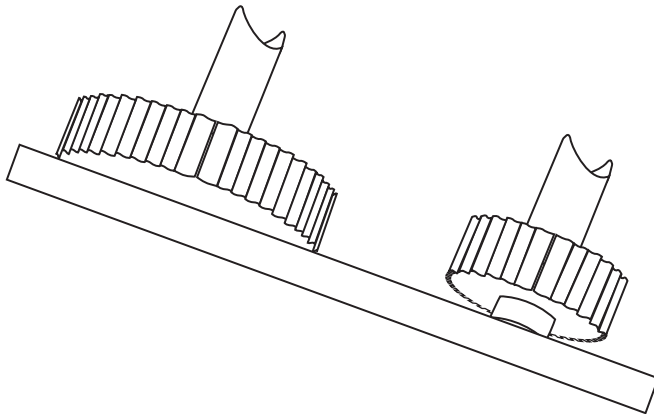

Misalignment also occurs when the shafts are not parallel as in Figure B.

Figure B

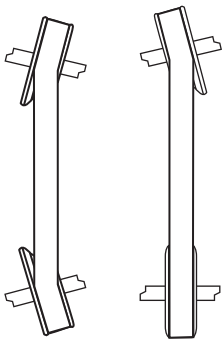

Laser Alignment Tool

With our Laser Alignment Tool, you can quickly align drive components to improve efficiency and reduce costly maintenance. Much easier to use than a straight edge, it attaches in seconds and when the highly-visible sight line lies within the target openings, the pulley/sprockets are aligned.

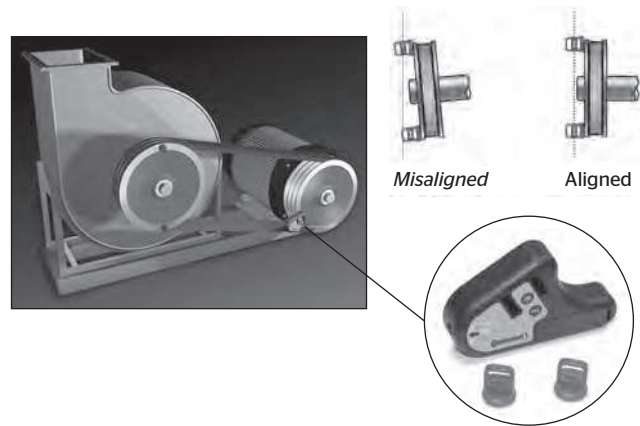

10. Identify correct belts

Always select belts to match sprocket profile. SilentSync® belts and sprockets are identified with a unique Color Spectrum System. The seven colors used for identification are: Yellow, White, Purple, Blue, Green, Orange and Red. Each color represents a different size so that Blue belts are made to operate with Blue sprockets. Make sure to obtain the same color belt and sprockets. When installing other synchronous belts, use the correct sprocket width.

11. Matching belts

Drives using synchronous belts are not recommended to run in matched sets. If a special application requires matching, specify "matched belts" on the order. Note: such requests require additional order lead time. Also, matching code numbers will not appear on the belts.

Synchronous Belts Installation Guide

12. How to install belts

Before installation, inspect the belt for damage. Belts should never appear crimped or bent to a diameter less than the minimum recommended sprocket diameter.

Always move the drive unit so you can easily slip the belts into the grooves without force.

Shorten the center distance or release the tensioning idler to install the belt. Do not pry the belt on the sprocket. Refer to the following Center Distance Allowance tables for the required center distance adjustment.

Place the belt on each sprocket and ensure proper engagement between the sprocket and belt teeth.

Lengthen the center distance or adjust the tensioning idler to remove any belt slack.

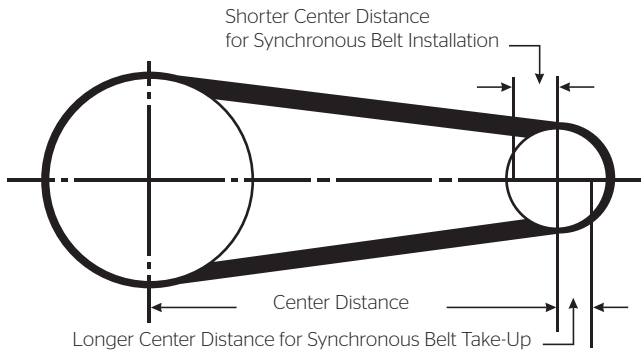

Apply the following center distance allowances for Hawk Pd® and Falcon Pd®. A center distance adjustment or decrease in center distance, is necessary to install a belt. In addition, an increase in center distance will be necessary for proper tensioning. If you install a belt together with sprockets, allow the following decrease in center distance for installation and an increase in center distance for tensioning.

Pitch Length Range (mm)	Allowance (decrease) for Installation	Allowance (increase) for Take-Up
	8m, 14m Belts (mm/in.)	8m, 14m Belts (mm/in.)
Less than 1525	2.5/0.1	2.5/0.1
1525-3050	5.0/0.2	5.0/0.2
Greater than 3050	7.5/0.3	7.5/0.3

If you install a belt over one flanged sprocket and one unflanged sprocket with the sprockets already installed on the drive, allow the following decrease in center distance for installation and increase in center distance for tensioning.

Pitch Length Range (mm)	Allowance (decrease) for Installation		Allowance (increase) for Take-Up
	8m Belts (mm/in.)	14m Belts (mm/in.)	8m, 14m Belts (mm/in.)
Less than 1525	22.5/0.9	36.5/1.4	2.5/0.1
1525-3050	25.0/1.0	39.0/1.5	5.0/0.2
Greater than 3050	27.5/1.1	41.5/1.6	7.5/0.3

If you install the belt over two flanged sprockets that are already installed on the drive, allow the following decrease in center distance for installation and increase in center distance for tensioning:

Pitch Length Range (mm)	Allowance (decrease) for Installation		Allowance (increase) for Take-Up
	8m Belts (mm/in.)	14m Belts (mm/in.)	8m, 14m Belts (mm/in.)
Less than 1525	34.5/1.4	59.2/2.3	2.5/0.1
1525-3050	37.0/1.5	62.0/2.4	5.0/0.2
Greater than 3050	39.5/1.6	64.5/2.5	7.5/0.3

Consider the following center distance allowances when installing SilentSync® sprockets.

Since flanges are not necessary on SilentSync® drives, only one table of center distance allowances is provided.

Pitch Length Range (mm)	Allowance (decrease) for Installation		Allowance (increase) for Take-Up
	Yellow, White, Purple Belts (mm/in.)	Blue, Green, Orange, Red (mm/in.)	8m, 14m Belts (mm/in.)
Less than 1525	10.1/0.4	15.2/0.6	2.5/0.1
Greater than 1525	15.2/0.6	17.8/0.7	5.0/0.2

13. Tension

Install and tension synchronous belts properly to ensure optimum performance.

Proper tension is essential for maximum belt life and efficiency. Improper belt tension is the primary cause of premature belt failure and increased costs. Under-tensioned belts lead to ratcheting and excessive tooth loading, both of which lead to higher maintenance costs and inefficient transmission of power. Also, over-tensioning belts leads to premature wear, along with bearing, shaft and sprocket problems. The result is more frequent replacement of drive components and costly downtime.

Tensioning Methods

Choose one of two tensioning methods for Synchronous belts:

TensionRite® Belt Frequency Meter

Using advanced optical technology, our TensionRite® Belt Frequency Meter provides a simple, repeatable and reliable method for tensioning belts. It displays the natural vibration frequency of the belt strand so you can closely monitor belt tension. The device works with all industrial transmission belts including V-belts, synchronous belts, banded belts and Poly-V® belts and calculates the corresponding belt tension in either English or SI units.



Deflection Principle

Plunger-type gauges utilize the deflection principle to check the tension of a belt drive.



The gauge deflects the center of the belt span and the force of this deflection is compared to a target deflection force for the particular span. Then, one can adjust the belt tension until the actual deflection force equals the target.

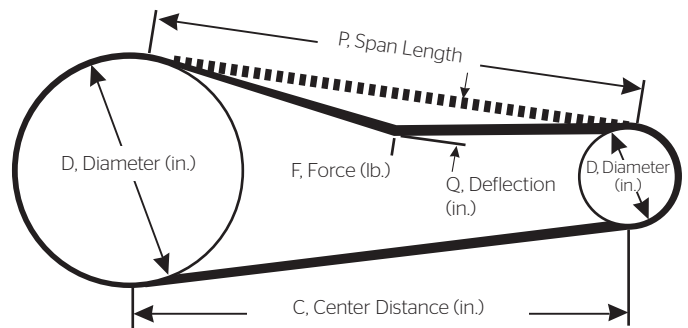

$$P = \frac{D-d}{2 \tan \left[\sin^{-1} \left(\frac{D-d}{2C} \right) \right]}$$

(in.)

Where: P = Span length

C = Center distance

D = Large pulley pitch diameter

d = Small pulley pitch diameter

Synchronous Belts

Installation Guide

First, determine the proper deflection force to tension the belt. Deflection forces are listed in Table 18. Deflection forces are also given on the output of the MaximizerPro™ computer drive analysis.

If using a tension gauge, the deflection scale is calibrated in inches of span length. Check the force required to deflect the belt the proper amount. There is an O-ring to help record the force. If the measured force is less than the required deflection force, lengthen the center distance. If the measured force is greater than the required deflection force, shorten the center distance.

If using other means to apply force to the belt, adjust the center distance so that the belt is deflected 1/64 inch per inch of span length when the proper force is applied. After the belt is properly tensioned, lock down the center distance adjustments and recheck the sprocket alignment.

If possible, run the drive for approximately 5 minutes with or without load. Stop the drive, lock out the power source and examine alignment, capscrew torque and belt tension of the drive. Adjust the center distance to increase the belt tension to the “new” value in the Deflection Force Tables. Lock down the drive adjustments and recheck tension. Recheck the belt tension, alignment and capscrew torque after 8 hours of operation to ensure the drive has not shifted.

Table 18 Deflection Forces for Belt Tensioning

Belt Type	0-100 RPM		101-1000 RPM		1000-Up RPM	
	New Belt	Used Belt	New Belt	Used Belt	New Belt	Used Belt
SilentSync®						
Yellow	15	11	12	8	9	7
White	30	21	24	17	19	13
Purple	60	43	47	34	38	27
Blue	54	38	44	31	38	27
Green	60	57	66	47	57	41
Orange	107	76	88	63	76	55
Red	161	115	131	94	115	82
Falcon Pd®						
8GTR 12	24	17	14	10	9	7
8GTR 21	42	30	25	18	16	12
8GTR 36	72	51	42	30	27	21
8GTR 62	124	88	72	52	47	36
14GTR 20	38	29	31	23	28	21
14GTR 37	70	54	57	43	52	39
14GTR 68	129	99	105	78	95	71
14GTR 90	171	131	140	104	126	95
14GTR 125	238	181	194	144	175	131
Blackhawk Pd®						
8MBH12	12	9	9	7	7	5
8MBH 22	23	17	16	12	13	10
8MBH 35	36	26	26	19	21	16
8MBH 60	62	45	45	33	36	27
14MBH 20	36	26	27	20	23	17
14MBH 42	76	55	57	42	49	36
14MBH 65	117	85	89	65	76	55
14MBH 90	162	118	123	90	105	77
14MBH 120	217	157	164	119	139	102
Hawk Pd®						
8M 20	15	11	13	10	12	9
8M 30	23	17	20	15	19	14
8M 50	39	29	35	26	32	24
8M 85	69	50	61	45	56	41
14M 40	47	34	38	28	32	24
14M 55	70	51	56	41	48	35
14M 85	116	84	93	68	79	58
14M 115	162	118	130	95	110	80
14M 170	249	181	201	146	171	125

The following few sections detail other issues that could arise during synchronous belt installation:

14. Using a fixed center distance

A fixed center distance drive has no adjustment for tensioning or installing the belt. Due to the tolerances of drive components, including sprocket, belt and drive geometry, a drive with a Fixed Center Distance is not recommended as adequate belt tension cannot be assured. Proper belt installation requires a minimum center to center adjustment (refer to belt installation for center to center adjustment on page 39). In some cases, fixed center drives cannot be avoided and should be used only with the understanding that belt life will be reduced.

15. Design factors

To ensure proper belt selection, consult the appropriate design manual for SilentSync®, Blackhawk Pd®, Falcon Pd® or Hawk Pd®. Due to the high load capacity of these belts, make sure that all of the drive components are adequately designed. Consult sprocket and other component manufacturers for design assistance or if verification of application is needed.

16. Belt guards

Belt guards ensure cleanliness and safety. Screened, meshed, or grilled guards are preferable because they allow for air circulation and heat escape.

17. Idlers

Use idlers either inside or outside of the belt, preferably outside. Idlers often function as a tensioning mechanism when the drive has a fixed center distance. When an idler is necessary, follow several general rules:

Locate the idler on the slack side of the belt.

Small, inside idlers should be grooved (up to 40 teeth).

Outside idlers should be flat, not crowned.

Minimum idler diameter should be 4 inches on 8mm pitch drives and 8 inches on 14mm pitch drives.

Hold idler arc of contact to a minimum.

Do not use spring loaded tensioners.

Lock idlers firmly in place to minimize movement or deflection during drive start-up and operation.

18. Teeth in mesh

Sprockets with low belt angle of less than 60 degrees or less than six teeth in mesh (TIM) will not transmit the full rated load. Should drives be designed using less than six teeth in mesh, the service life of the belt will be reduced.

19. Flanged sprockets

Use flanges to keep the belt in the sprocket and prevent "rideoff" as each belt has its own tracking characteristics. Even belts with perfect drive alignment can have a tracking problem.

Synchronous belts will have an inherent side thrust while in motion and can be controlled with flanged sprockets. If side thrust is severe, check the drive for sprocket alignment, parallel shafts and shaft deflection.

For a two sprocket drive:

A minimum requirement should be two flanges on one sprocket for economical reasons; the smaller sprocket is usually flanged.

When the center distance of the drive exceeds eight times the diameter of the smaller sprocket, it is suggested that flanges be included on both sides of each sprocket.

On vertical shaft drives, one sprocket should be flanged on both sides and one sprocket flanged on bottom side only.

For a multiple sprocket drive:

Two flanges are required on every other sprocket or a single flange on every sprocket, altering sides.

20. Multiple sprocket drives

Multiple sprocket drives typically have one DriveR and two or more DriveN sprockets. In these cases, it is acceptable to size the drive based on the most severely loaded shaft. This is usually the DriveR shaft since the load of all the DriveN shafts must be transmitted through one DriveR shaft. Sprockets with a low belt wrap angle, less than 60 degrees and/or a low number of teeth in mesh, less than six teeth, will not transmit full rated load and service life of the belt will be reduced.

The number of teeth in mesh is equal to Belt Wrap in mm/Pitch in mm. Backside idlers can be used to increase belt wrap (see Table 17 on page 36). For detailed multiple sprocket drive design, contact a drive design specialist at Continental ContiTech.

21. Bearing loads

On many drives, bearing life is a concern. Reducing the bearing load will increase bearing life. Bearing loads can be reduced in the following ways:

Calculate the belt tension instead of using the belt tensioning tables. The tables are general and may specify higher belt tension than is necessary on some drives. Contact your Distributor to assist in calculating actual belt tension requirements for your drive.

Larger diameter sprockets will require less belt tension on any given drive.

Always position the sprockets close to the bearings. This positioning will reduce the effect of the "overhung" bearing load. Be sure not to install a belt at less than the recommended tension. A belt that is under-tensioned will have a reduced service life.

Maintenance Installation Guide

Belt drives are a reliable and efficient means of power transmission. Since they are essentially trouble-free, they are ignored often and do not receive the minimal attention they require for the full delivery of benefits over the course of a long life of use.

Belt drive maintenance is neither complicated nor does it require a great deal of time or a large variety of special tools. Primarily, good maintenance requires that you look at and listen to the drive to discover and correct any problems.

What to look for:

Oil and grease

Police a drive well. Immediately repair leaky bearings as excess oil on a bearing will splash on the belts. If you cannot correct these conditions without sacrificing adequate lubrication, use oil-resistant belts as too little lubrication will cause bearing failure, which may also cause belt failure when drag becomes excessive.

Dirt

No equipment operates best when it is dirty. Belts are no exception. Dirt accelerates belt wear and dirt build-up in a V-belt sheave groove impairs traction.

Added loads

Check to see that no additional loads have been added since the original drive was selected.

Belt guards

Belt guards ensure that large debris does not enter the drive.

Cracking

Reduce V-belt bottom cracking by using larger sheaves and larger reverse bend idler sheaves; however, tooth cracking on synchronous belts is an early indicator of tooth shear, and therefore, the belt should be replaced. See Troubleshooting charts for corrective action.

Belt dressing

Belt dressing is seldom beneficial to belt drives. This tackiness actually accelerates the time to failure of V-belts. If V-belts slip or squeak, identify and correct the problem. Never use belt dressing on synchronous belts.

Vibration

Excessive vibration should be minimized. This is often due to low tension or damaged tensile member. In extreme cases, a

Prevent Belt Whipping

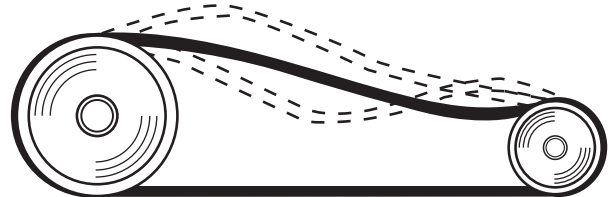

back side kiss idler may need to be added in the vibrating span.

Tension

Tension is critical in belt drives. For V-belts, the ideal tension is the lowest tension at which the belts will not slip under peak load conditions. For synchronous belts, under-tensioning leads to ratcheting and excessive tooth loading. Adjust tension to the values shown in the tables provided in this guide. See section on "Installation" for the type of belt involved for additional information.

Heat

High temperatures cause heat-aging and shorten belt life. Check frequently belts operating in temperatures above 180°F (82.2°C) and consider special heat-resistant construction if belt life is not satisfactory.

Belt turn over

Turned over V-belts indicate drive misalignment, worn sheaves or excessive vibration.

Change in ride out

Ride out is the position of the top of the V-belt to the outside diameter of the sheave. A change in ride out over time indicates uneven belt wear or worn sheaves.

Lateral vibration

Don't allow belts to snake.

Belt wear

Wear on V-belt sidewalls indicates consistent slippage, excessive dust or rough sheaves. Tooth wear on synchronous belts is an indication of improper tooth meshing. See Troubleshooting (on pages 46-48) for possible causes and corrections.

Debris

Broken belts or excessive vibration can result from the presence of foreign material on the belts or in the sheaves or sprockets.

Maintenance Installation Guide

What to listen for:

Squeal

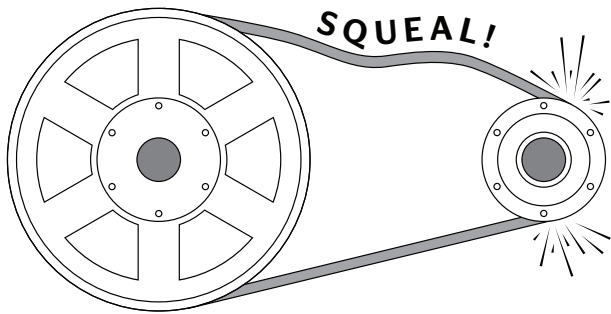

Squeal is usually a result of insufficient belt tension requiring prompt investigation. If squeal persists after checking all belts and adjusting tension, examine the drive itself for overloading.

Chirp

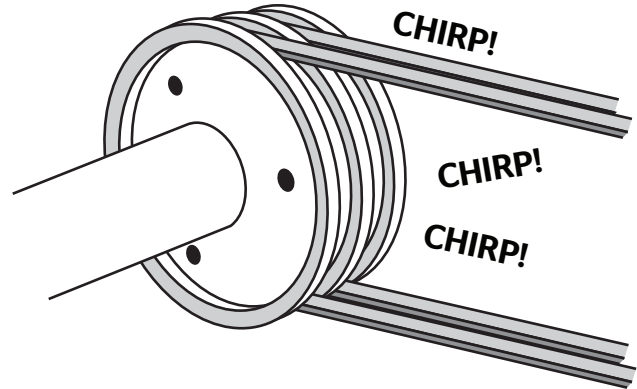

Chirp, a sound like that of a chirping bird, can occur on all types of belt drives. Never apply dressing or oil to a belt in an effort to eliminate chirps or squeaks. Realignment of an idler may help.

Troubleshooting

V-Belts Performance Analysis

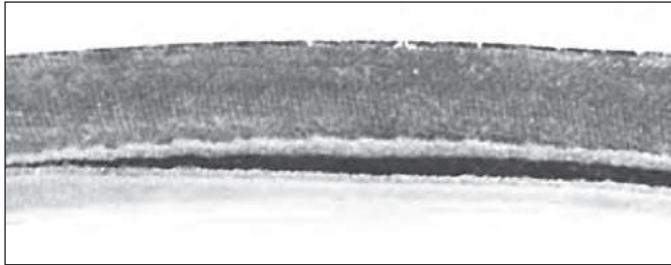

Cause of Failure - Excessive exposure to oil or grease has caused the belt to swell, become soft and the bottom envelope seam to “open up.”

Correction - Provide splash guards, do not over lubricate and clean belts and sheaves with gasoline.



Cause of Failure - Belt has evenly spaced deep bottom cracks from use of a substandard backside idler.

Correction - Replace backside idler with the minimum size recommendation.

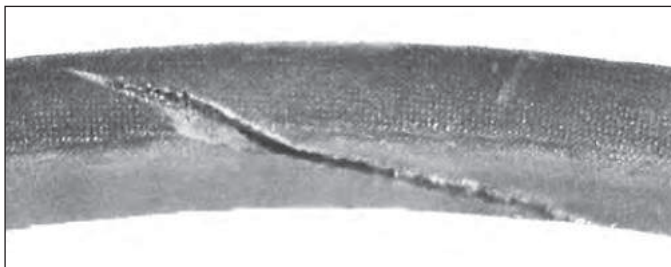

Cause of Failure - Cut bottom and sidewall indicate belt was pried over sheave and damaged during installation.

Correction - Be sure to use proper length belt and move tensioning all the way “in” when installing belt.



Cause of Failure - Weathering or “crazing” caused by the elements and aggravated by small sheaves.

Correction - Provide protection for the drive and replace belt or belts.



Cause of Failure - Constant slippage caused by insufficient tension in belt.

Correction - Tension drive in accordance with the recommendations of the equipment manufacturer and this manual.

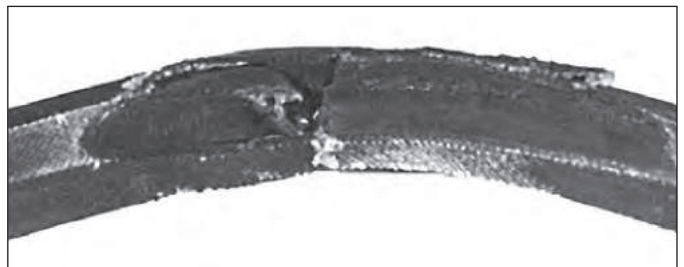

Cause of Failure - Severe localized wear caused by a frozen or locked driven sheave.

Correction - Determine that the drive components turn freely and tighten belt, if necessary.

Troubleshooting

V-Belts Performance Analysis



Cause of Failure - Split on side at the belt pitch line indicates use of a sheave with a substandard diameter.

Correction - Redesigning drive to utilize proper size sheaves.

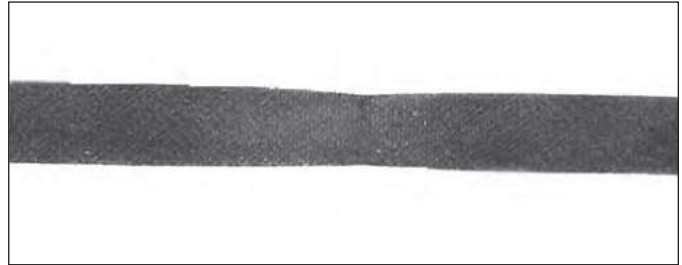

Cause of Failure - The load carrying member has been broken by a shock load or damage during installation.

Correction - Maintain proper tensioning and observe proper installation procedures.



Cause of Failure - Rough sheave sidewalls cause the cover to wear off in an uneven pattern.

Correction - File or machine out the rough spot on the sheave groove. If beyond repair, replace the sheave.

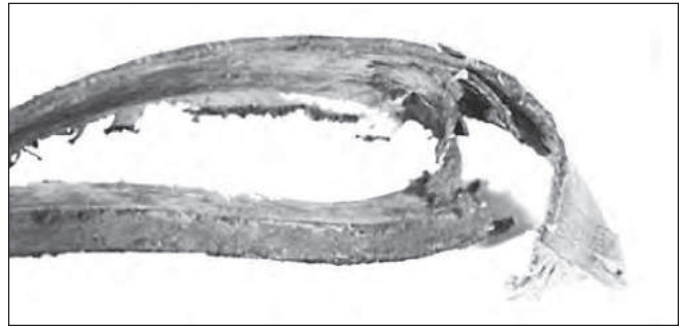

Cause of Failure - Excessive dust and rough sheaves combine to cause severe envelope wear and early belt failure.

Correction - Maintain sheave condition, alignment and attempt to protect drive from excessive dust exposure.



Cause of Failure - Ply separation caused by substandard sheave diameter.

Correction - Redesign drive to use proper-sized sheaves.

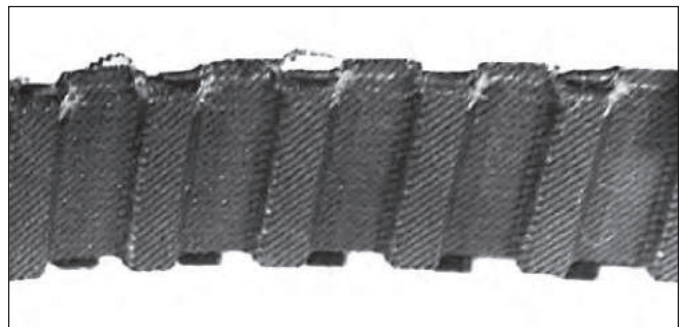

Cause of Failure - Flange wear on Pd synchronous belt.

Correction - Adjust and maintain proper pulley alignment.



Cause of Failure - Tensile breaks can be caused by high shock loads, foreign object between the bottom of the sheave and the bottom of the belt or damage during installation.

Correction - Maintain proper drive tension and installation procedures. Provide guard to keep foreign material from coming in contact with the drive.

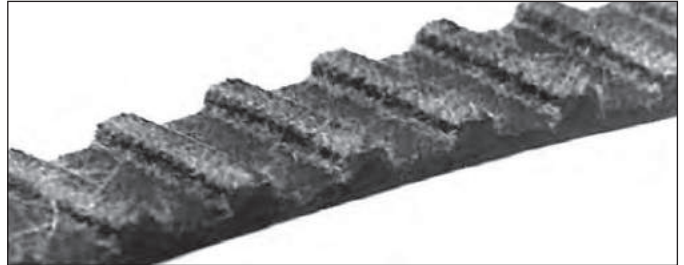

Cause of Failure - Tooth shear caused by belt overload condition from improper application or shock loads.

Correction - Consult engineering manual to proper application and maintain proper belt tension.



Cause of Failure - Back of the belt has been rubbing on a belt guard or other appurtenance.

Correction - Provide adequate clearance between belt and guard or any appurtenances.



Cause of Failure - Web fabric wear caused by improper belt and pulley fit.

Correction - Check belt/pulley fit and replace worn or out-of-spec pulleys.



Cause of Failure - Worn sheave grooves allow the joined belt to ride too low cutting through to the top band.

Correction - Replace sheaves and maintain proper belt tension and sheave alignment.

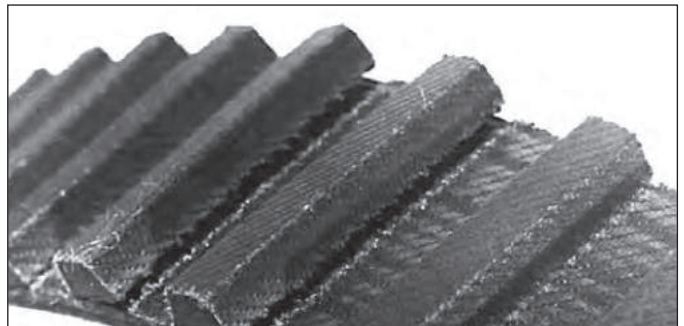

Cause of Failure - Fabric wear caused by insufficient belt tension or pulleys which are not to the standard Pd pulley dimensions and tolerances.

Correction - Maintain proper tension and replace the out-of-spec pulleys.

Troubleshooting

V-Belts Systems

Problem	Problem								
	Cut Thru on Top (Joined Belts)	Mismatched Belts at Installation	Belts too Short at Installation	Belts too Long at Installation	Excessive Vibration	Excessive Stretch	Belt Squeal	Hardening & Premature Cracking	Belts Turn Over
Possible Causes									
Excessive Oil									
Exposure to Elements									
Pried Over Sheaves									
Contact with Obstruction									
Insufficient Tension									
Stalled Drive Sheaves									
Constant Slippage									
Rough Sheaves									
Substandard Sheaves									
Excessive Tension									
Shock Load									
Foreign Material									
Excessive Dust									
Drive Misalignment									
Worn Sheaves									
Excessive Vibration									
High Ambient Temperature									
Drive Underbelted									
Damaged Tensile Member									
Incorrect Belts									
Incorrect Drive Set-Up									
Insufficient Take-Up									
Improper Matching									
Mixed Old and New Belts									
Non-Parallel Shafts									
Different Manufacturers									
Belt/Pulley, Incompatible									
Corrective Action									
Lubricate properly									
Clean sheaves and belt									
Replace belts									
Provide protection									
Install properly									
Check for belt length									
Remove obstruction									
Tension properly									
Free sheaves									
Replace sheaves									
File smooth									
Redesign drive									
Operate properly									
Align drive									
Provide ventilation									
Check for proper belt									
Check machinery									
Use only new belts									
Use single source									
Check fit									
Replace pulleys									

Troubleshooting

Synchronous Belts Systems

Types of Failure

Possible Cause of Failure	Excessive Edge Wear	Excessive Tooth Wear	Uneven Tooth Wear	Apparent Belt Stretch	Cracks in Backing	Tooth Shear	Tensile Failure	Excessive Drive Noise	Tooth Skipping (Ratcheting)	Belt Tracking	Excessive Sprocket Wear	Excessive Drive Vibration
Belt Hitting Obstruction	Primary Cause	Could Cause But Not Likely	Possible Cause					Could Cause But Not Likely				Could Cause But Not Likely
Excessive Load		Possible Cause				Primary Cause	Primary Cause					
Belt Overtensioned		Could Cause But Not Likely					Possible Cause	Could Cause But Not Likely			Could Cause But Not Likely	Could Cause But Not Likely
Belt Undertensioned		Primary Cause	Possible Cause	Could Cause But Not Likely				Possible Cause	Primary Cause			Could Cause But Not Likely
Rough or Damaged Sprocket		Possible Cause	Possible Cause									Could Cause But Not Likely
Misalignment		Primary Cause	Primary Cause			Possible Cause	Primary Cause			Primary Cause	Could Cause But Not Likely	
Worn Sprocket		Possible Cause	Possible Cause			Could Cause But Not Likely			Could Cause But Not Likely			
Sprocket Out of Tolerance		Could Cause But Not Likely	Could Cause But Not Likely			Could Cause But Not Likely			Could Cause But Not Likely	Could Cause But Not Likely	Could Cause But Not Likely	Could Cause But Not Likely
Soft Sprocket Material											Primary Cause	
Debris in Sprocket or Drive		Possible Cause	Could Cause But Not Likely			Could Cause But Not Likely	Possible Cause		Could Cause But Not Likely	Possible Cause	Primary Cause	Possible Cause
Center Distance Changed		Could Cause But Not Likely		Primary Cause					Possible Cause			
Weak Drive Structure		Could Cause But Not Likely		Primary Cause				Could Cause But Not Likely	Possible Cause	Possible Cause		Primary Cause
Excessive Low Temperature					Primary Cause	Could Cause But Not Likely						
Excessive High Temperature				Could Cause But Not Likely	Primary Cause	Could Cause But Not Likely						Could Cause But Not Likely
Exposure to Oil, Solvents, Chemicals				Possible Cause	Possible Cause	Could Cause But Not Likely	Could Cause But Not Likely	Could Cause But Not Likely	Could Cause But Not Likely		Could Cause But Not Likely	
Sprocket Diameter Sub Minimum				Could Cause But Not Likely	Primary Cause		Possible Cause					
Back Side Idler					Possible Cause							
Shock Loading					Possible Cause	Primary Cause	Possible Cause		Could Cause But Not Likely			
Less than 6 Teeth in Mesh		Could Cause But Not Likely	Could Cause But Not Likely			Possible Cause						
Excessive Sprocket Runout							Could Cause But Not Likely					Possible Cause
Damage Due to Handling							Primary Cause				Could Cause But Not Likely	
Vibrating Bearings/ Mountings												Possible Cause
Center Distance Greater than 8x Small Sprocket Diameter										Could Cause But Not Likely		
Sprocket Not Properly Balanced								Could Cause But Not Likely				Primary Cause
Belt/Sprocket Incompatible		Possible Cause				Could Cause But Not Likely		Could Cause But Not Likely			Could Cause But Not Likely	Possible Cause

Legend
 Primary Cause
 Possible Cause
 Could Cause But Not Likely

continued on page 52

Types of Failure (continued)

	Excessive Edge Wear	Excessive Tooth Wear	Uneven Tooth Wear	Apparent Belt Stretch	Cracks in Backing	Tooth Shear	Tensile Failure	Excessive Drive Noise	Tooth Skipping (Ratcheting)	Belt Tracking	Excessive Sprocket Wear	Excessive Drive Vibration
Corrective Action												
Remove obstruction or use idler to reroute belt	Primary Cause	Could Cause But Not Likely	Possible Cause					Could Cause But Not Likely				Could Cause But Not Likely
Redesign drive		Possible Cause				Primary Cause	Could Cause But Not Likely					
Use tensioning gauge to set proper tension		Could Cause But Not Likely					Possible Cause	Could Cause But Not Likely			Could Cause But Not Likely	Could Cause But Not Likely
Use tensioning gauge to set proper tension		Primary Cause	Possible Cause	Could Cause But Not Likely				Could Cause But Not Likely	Primary Cause			Could Cause But Not Likely
Replace sprocket		Possible Cause	Possible Cause									Could Cause But Not Likely
Align shafts and sprockets		Primary Cause	Primary Cause			Possible Cause	Primary Cause			Primary Cause	Could Cause But Not Likely	
Replace sprocket		Possible Cause	Possible Cause			Could Cause But Not Likely			Could Cause But Not Likely			
Replace sprocket, never attempt to remachine		Could Cause But Not Likely	Could Cause But Not Likely			Could Cause But Not Likely			Could Cause But Not Likely	Could Cause But Not Likely	Could Cause But Not Likely	Could Cause But Not Likely
Use harder sprocket material											Primary Cause	
Shield drive		Possible Cause	Could Cause But Not Likely			Could Cause But Not Likely	Possible Cause		Could Cause But Not Likely	Possible Cause	Primary Cause	Possible Cause
Check lock down bolts on motors and shafts		Could Cause But Not Likely		Primary Cause					Could Cause But Not Likely			
Reinforce drive structure		Could Cause But Not Likely		Primary Cause				Could Cause But Not Likely	Could Cause But Not Likely	Possible Cause		Primary Cause
Moderate temperature, especially at startup					Primary Cause	Could Cause But Not Likely						
Moderate temperature, shield drive				Could Cause But Not Likely	Primary Cause	Could Cause But Not Likely						Could Cause But Not Likely
Shield drive, eliminate chemicals				Possible Cause	Possible Cause	Could Cause But Not Likely	Could Cause But Not Likely		Could Cause But Not Likely		Could Cause But Not Likely	
Redesign drive to increased sprocket diameters				Could Cause But Not Likely	Primary Cause		Possible Cause					
Redesign to reduce wrap on backside idler					Possible Cause							
Eliminate shock loading or redesign drive to handle it					Possible Cause	Primary Cause	Possible Cause		Could Cause But Not Likely			
Increase wrap on sprocket		Could Cause But Not Likely	Could Cause But Not Likely			Possible Cause						
Replace sprocket							Could Cause But Not Likely					Possible Cause
Replace product, do not crimp belt or drop sprockets							Primary Cause				Could Cause But Not Likely	
Replace bearings or reinforce mountings												Possible Cause
Alignment is critical										Possible Cause		
Check sprocket balance								Could Cause But Not Likely				Primary Cause
Check for proper belt		Possible Cause				Possible Cause		Could Cause But Not Likely			Could Cause But Not Likely	Possible Cause

Legend

Primary Cause
 Possible Cause
 Could Cause But Not Likely

Synchronous Belts Tensioning Tables

Synchronous Belt Tensioning Tables

Deflection Forces for Belt Tensioning (lb.)

Belt Type	0-100 RPM		101-1000 RPM		1000-Up RPM	
	New Belt	Used Belt	New Belt	Used Belt	New Belt	Used Belt
SilentSync®						
Yellow	15	11	12	8	9	7
White	30	21	24	17	19	13
Purple	60	43	47	34	38	27
Blue	54	38	44	31	38	27
Green	80	57	66	47	57	41
Orange	107	76	88	63	76	55
Red	161	115	131	94	115	82
Falcon Pd®						
8GTR 12	24	17	14	10	9	7
8GTR 21	42	30	25	18	16	12
8GTR 36	72	51	42	30	27	21
8GTR 62	124	88	72	52	47	36
14GTR 20	38	29	31	23	28	21
14GTR 37	70	54	57	43	52	39
14GTR 68	129	99	105	78	95	71
14GTR 90	171	131	140	104	126	95
14GTR 125	238	181	194	144	175	131
Blackhawk Pd®						
8MBH12	12	9	9	7	7	5
8MBH 22	23	17	16	12	13	10
8MBH 35	36	26	26	19	21	16
8MBH 60	62	45	45	33	36	27
14MBH 20	36	26	27	20	23	17
14MBH 42	76	55	57	42	49	36
14MBH 65	117	85	89	65	76	55
14MBH 90	162	118	123	90	105	77
14MBH 120	217	157	164	119	139	102
Hawk Pd®						
8M 20	15	11	13	10	12	9
8M 30	23	17	20	15	19	14
8M 50	39	29	35	26	32	24
8M 85	69	50	61	45	56	41
14M 40	47	34	38	28	32	24
14M 55	70	51	56	41	48	35
14M 85	116	84	93	68	79	58
14M 115	162	118	130	95	110	80
14M 170	249	181	201	146	171	125

Synchronous Belts Tensioning Tables

Belt Strand Tension (lb.)

Belt Type	0-100 RPM		101-1000 RPM		1000-Up RPM		Belt Weight (kg/m)
	New Belt	Used Belt	New Belt	Used Belt	New Belt	Used Belt	
SilentSync®							
Yellow	224	160	176	112	128	96	0.073
White	449	305	353	241	273	177	0.147
Purple	897	625	689	481	545	369	0.293
Blue	817	561	657	449	561	385	0.261
Green	1210	842	986	682	842	586	0.392
Orange	1618	1122	1314	914	1122	786	0.523
Red	2436	1700	1956	1364	1700	1172	0.784
Falcon Pd®							
8GTR 12	370	258	210	146	130	98	0.056
8GTR 21	648	456	376	264	232	168	0.093
8GTR 36	1111	775	631	439	391	295	0.167
8GTR 62	1913	1337	1081	761	681	505	0.288
14GTR 20	571	427	459	331	411	299	0.158
14GTR 37	1052	796	844	620	764	556	0.292
14GTR 68	1939	1459	1555	1123	1395	1011	0.537
14GTR 90	2570	1930	2074	1498	1850	1354	0.711
14GTR 125	3578	2666	2874	2074	2570	1866	0.987
Blackhawk Pd®							
8MBH12	179	131	131	99	99	67	0.057
8MBH 22	345	249	233	169	185	137	0.104
BMBH 35	539	379	379	267	299	219	0.165
8MBH 60	928	656	656	464	512	368	0.283
14MBH 20	553	393	409	297	345	249	0.157
14MBH 42	1167	831	863	623	735	527	0.330
14MBH 65	1796	1284	1348	964	1140	804	0.510
14MBH 90	2487	1783	1863	1335	1575	1127	0.706
14MBH 120	3332	2372	2484	1764	2084	1492	0.941
Hawk Pd®							
8M 20	226	162	194	146	178	130	0.118
8M 30	347	251	299	219	283	203	0.176
BM 50	590	430	526	382	478	350	0.289
8M 85	1046	742	918	662	838	598	0.507
14M 40	715	507	571	411	475	347	0.438
14M 55	1069	765	845	605	717	509	0.583
14M 85	1778	1266	1410	1010	1186	850	0.913
14M 115	2486	1782	1974	1414	1654	1174	1.233
14M 170	3827	2739	3059	2179	2579	1843	1.835

1. The table deflection forces and strand tensions are typically at maximum values to cover the broad range of loads, rpm and pulley combinations for all possible drives.
 2. For drives where hub loads are critical, high speed drives or other drives with special circumstances, the belt deflection force and strand installation tension should be calculated by using formulas found in existing engineering manuals or use the MaximizerPro™ Drive Selection Analysis Program.

3. Consult the TensionRite® Belt Frequency Meter manual for detailed information on using the frequency based tension gauge.
 4. Continental ContiTech offers three different levels of tension gauges to aid you in properly tensioning your power transmission belts. See your Sales Representative or Distributor for more information on tensioning gauges.

Wedge TLP™ V-Belts

Tensioning Tables

Deflection Forces for Belt Tensioning (lb.)

Smallest Sheave Diameter Range	RPM Range	New Belt	Used Belt
3VT - Belt Type			
2.65-3.65	1000-2500	5.4	4.6
2.65-3.65	2501-4000	4.7	4.0
4.12-6.9	1000-2500	7.6	6.3
4.12-6.9	2501-4000	6.9	5.8
5VT - Belt Type			
7.1-10.9	500-1740	22.1	18.5
7.1-10.9	1741-3000	19.6	16.4
11.8-16	500-1740	25.8	21.6
11.8-16	1741-3000	23.2	19.4
8VT - Belt Type			
12.5-17.0	200-850	51.6	43.1
12.5-17.0	851-1500	42.2	35.3
18.0-22.4	200-850	61.4	51.3
18.0-22.4	851-1500	55.2	46.1

Belt Strand Tension (lb.)

New Belt	Used Belt	Belt Weight (kg/meter)
3VT - Belt Type		
83.8	69.8	3VT=0.082
72.4	60.3	
118	98.3	
107	89.2	
5VT - Belt Type		
348.2	290.2	5VT=0.212
308.9	257.4	
408.2	340.2	
366	305.0	
8VT - Belt Type		
813.6	678.0	8VT=0.565
662.7	552.2	
969.7	808.1	
871.1	725.9	

1. The table deflection forces and strand tensions are typically at maximum values to cover the broad range of loads, rpm and pulley combinations for all possible drives.
2. For drives where hub loads are critical, high speed drives or other drives with special circumstances, the belt deflection force and strand installation tension should be calculated by using formulas found in existing engineering manuals or use the MaximizerPro™ Drive Selection Analysis Program.
3. Consult the TensionRite® Belt Frequency Meter manual for detailed information on using the frequency based tension gauge.
4. Continental ContiTech offers three different levels of tension gauges to aid you in properly tensioning your power transmission belts. See your Sales Representative or Distributor for more information on tensioning gauges.

V-Belts Tensioning Tables

Deflection Forces for Belt Tensioning (lb.)

Smallest Sheave Diameter Range	RPM Range	Noncogged Single, Torque Team** & Torque Team Plus** Belts		Cogged Single & Torque Team**	
		New Belt	Used Belt	New Belt	Used Belt
A, AX Cross Section					
3.0-3.6	1000-2500	5.5	3.7	6.1	4.1
	2501-4000	4.2	2.8	5.0	3.4
3.8-4.8	1000-2500	6.8	4.5	7.4	5.0
	2501-4000	5.7	3.8	6.4	4.3
5.0-7.0	1000-2500	8.0	5.4	9.4	5.7
	2501-4000	7.0	4.7	7.6	5.1
B, BX Cross Section					
3.4-4.2	860-2500	N/A	N/A	7.2	4.9
	2501-4000	N/A	N/A	6.2	4.2
4.4-5.6	860-2500	7.9	5.3	10.5	7.1
	2501-4000	6.7	4.5	9.1	6.2
5.8-8.6	860-2500	9.4	6.3	12.6	8.5
	2501-4000	8.2	5.5	10.9	7.3
C, CX Cross Section					
7.0-9.0	500-1740	17.0	11.5	21.8	14.7
	1741-3000	13.8	9.4	17.5	11.9
9.5-16.0	500-1740	21.0	14.1	23.5	15.9
	1741-3000	18.5	12.5	21.6	14.6
D Cross Section					
12.0-16.0	200-850	37.0	24.9	N/A	N/A
	851-1500	31.3	21.2	N/A	N/A
18.0-20.0	200-850	45.2	30.4	N/A	N/A
	851-1500	38.0	25.6	N/A	N/A
3V, 3VX, XPZ Cross Section					
2.2-2.4	1000-2500	N/A	N/A	4.9	3.3
	2501-4000	N/A	N/A	4.3	2.9
2.65-3.65	1000-2500	5.1	3.6	6.2	4.2
	2501-4000	4.4	3.0	5.6	3.8
4.12-6.90	1000-2500	7.3	4.9	7.9	5.3
	2501-4000	6.6	4.4	7.3	4.9
SPA, XPA Cross Section					
3.0-4.1	1000-2500	N/A	N/A	9.0	6.1
	2501-4000	N/A	N/A	7.9	5.2
4.2-5.7	1000-2500	10.1	6.7	12.4	8.3
	2501-4000	8.3	5.6	11.2	7.4
5.7-10.1	1000-2500	14.6	9.7	15.3	10.1
	2501-4000	12.6	8.5	13.7	9.2

Deflection Forces for Belt Tensioning (lb.)

Smallest Sheave Diameter Range	RPM Range	Noncogged Single, Torque Team** & Torque Team Plus** Belts		Cogged Single & Torque Team**	
		New Belt	Used Belt	New Belt	Used Belt
5V, 5VX, SPB, XPB Cross Section					
4.4-6.7	500-1749	N/A	N/A	15.2	10.2
	1750-3000	N/A	N/A	13.2	8.8
	3001-4000	N/A	N/A	8.5	5.6
7.1-10.9	500-1740	18.9	12.7	22.1	14.8
	1741-3000	16.7	11.2	20.1	13.7
11.8-16.0	500-1740	23.4	15.5	25.5	17.1
	1741-3000	21.8	14.6	25.0	16.8
SPC, XPC Cross Section					
8.3-14.3	500-1000	31.0	20.7	33.3	22.3
	1000-1750	28.6	19.1	32.4	21.6
14.4-20.1	500-1000	39.3	26.3	41.8	27.9
	1000-1750	37.5	25.2	45.6	30.3
8V, 8VX Cross Section					
12.5-17.0	200-850	49.3	33.0	N/A	N/A
	851-1500	39.9	26.8	N/A	N/A
18.0-22.4	200-850	59.2	39.6	N/A	N/A
	851-1500	52.7	35.3	N/A	N/A
5VF Cross Section					
7.1-10.9	200-700	30.9	21.1	N/A	N/A
	701-1250	26.3	18.0	N/A	N/A
	1251-1900	23.4	16.7	N/A	N/A
	1901-3000	23.0	15.8	N/A	N/A
11.8-16.0	200-700	39.5	26.8	N/A	N/A
	701-1250	34.7	23.5	N/A	N/A
	1251-2100	33.3	22.7	N/A	N/A
8VF Cross Section					
12.0-20.0	200-500	65.8	44.7	N/A	N/A
	501-850	56.6	38.5	N/A	N/A
	851-1150	51.6	35.2	N/A	N/A
	1151-1650	49.0	33.5	N/A	N/A
21.2-25.0	200-500	97.6	65.9	N/A	N/A
	501-850	90.6	61.2	N/A	N/A
	851-1200	84.3	57.0	N/A	N/A

*Multiply table values by the number of Torque Team® ribs to achieve recommended tensioning value.

1. The table deflection forces and strand tensions are typically at maximum values to cover the broad range of loads, rpm and pulley combinations for all possible drives.
2. For drives where hub loads are critical, high speed drives or other drives with special circumstances, the belt deflection force and strand installation tension should be calculated by using formulas found in existing engineering manuals or use the MaximizerPro™ Drive Selection Analysis Program.
3. Consult the TensionRite® Belt Frequency Meter manual for detailed information on using the frequency based tension gauge.
4. Continental ContiTech offers three different levels of tension gauges to aid you in properly tensioning your power transmission belts. See your Sales Representative or Distributor for more information on tensioning gauges.

Belt Strand Tension (lb.)

Smallest Sheave Diameter Range	RPM Range	Noncogged Single, Torque Team** & Torque Team Plus** Belts		Cogged Single & Torque Team**		Belt Weight (kg/meter)
		New Belt	Used Belt	New Belt	Used Belt	
A, AX Cross Section						
3.0-3.6	1000-2500	84	56	94	62	A=0.100
	2501-4000	64	41	76	51	
3.8-4.8	1000-2500	105	68	115	76	
	2501-4000	88	57	99	65	
5.0-7.0	1000-2500	124	83	147	88	AX=0.930
	2501-4000	108	72	118	78	
B, BX Cross Section						
3.4-4.2	860-2500	N/A	N/A	110.3	73.5	B=0.168
	2501-4000	N/A	N/A	94.3	62.3	Torque Team*
4.4-5.6	860-2500	121.5	79.9	163.1	108.7	B= 0.216x # ribs
	2501-4000	102.3	67.1	140.7	94.3	BX=0.161
5.8-8.6	860-2500	145.5	95.9	196.7	131.1	Torque Team*
	2501-4000	126.3	83.1	169.5	111.9	BX=0.211 x # ribs
C, CX Cross Section						
7.0-9.0	500-1740	264.8	176.6	341.4	227.8	C=0.296
	1741-3000	213.4	143.0	272.6	183.0	Torque Team* C=0.367 x # ribs
9.5-16.0	500-1740	328.6	218.2	368.6	247.0	CX=0.282
	1741-3000	288.6	192.6	338.2	226.2	Torque Team* CX=0.344 x # ribs
D Cross Section						
12.0-16.0	200-850	581.9	388.3	N/A	N/A	D=0.671
	851-1500	490.7	329.1	N/A	N/A	
18.0-20.0	200-850	713.1	476.3	N/A	N/A	Torque Team*
	851-1500	597.9	399.5	N/A	N/A	D=0.755 x # ribs
3V, 3VX, XPZ Cross Section						
2.2-2.4	1000-2500	N/A	N/A	75.9	50.3	3V=0.076
	2501-4000	N/A	N/A	66.3	43.9	Torque Team*
2.65-3.65	1000-2500	79.1	55.1	96.7	64.7	3V=0.094 x # ribs
	2501-4000	67.9	45.5	87.1	58.3	3VX, XPZ = 0.068
4.12-6.90	1000-2500	114.3	75.9	123.9	82.3	Torque Team*
	2501-4000	103.1	67.9	114.3	75.9	3VX=0.096 x # ribs
SPA, XPA Cross Section						
3.0-4.1	1000-2500	N/A	N/A	140.3	93.9	SPA=0.128
	2501-4000	N/A	N/A	122.7	79.5	
4.2-5.7	1000-2500	157.9	103.5	194.7	129.1	
	2501-4000	129.1	85.9	175.5	114.7	
5.7-10.1	1000-2500	229.9	151.5	241.1	157.9	XPA= 0.114
	2501-4000	197.9	132.3	215.5	143.5	

V-Belts

Tensioning Tables

Belt Strand Tension (lb.)

Smallest Sheave Diameter Range	RPM Range	Noncogged Single, Torque Team** & Torque Team Plus** Belts		Cogged Single & Torque Team**		Belt Weight (kg/meter)
		New Belt	Used Belt	New Belt	Used Belt	
5V, 5VX, SPB, XPB Cross Section						
4.4-6.7	500-1749	N/A	N/A	238.8	158.8	5V, SPB= 0.186
	1750-3000	N/A	N/A	206.8	136.4	Torque Team®
	3001-4000	N/A	N/A	131.6	85.2	5V=0.243 x # ribs
7.1-10.9	500-1740	298.0	198.8	349.2	232.4	5VX, XPB=0.149
	1741-3000	262.8	174.8	317.2	214.8	
11.8-16.0	500-1740	370.0	243.6	403.6	269.2	Torque Team®
	1741-3000	344.4	229.2	395.6	264.4	5VX=0.217 x # ribs
SPC, XPC Cross Section						
8.3-14.3	500-1000	488.6	323.8	525.4	349.4	SPC=0.372
	1000-1750	450.2	298.2	511.0	338.2	
14.4-20.1	500-1000	621.4	413.4	661.4	439.0	XPC=0.289
	1000-1750	592.6	395.8	722.2	477.4	
8V, 8VX Cross Section						
12.5-17.0	200-850	779.3	518.5	N/A	N/A	8V=0.495
	851-1500	628.9	419.3	N/A	N/A	Torque Team®
18.0-22.4	200-850	937.7	624.1	N/A	N/A	BV=0.546 x # ribs
	851-1500	833.7	555.3	N/A	N/A	8VX= 0.486
5VF Cross Section						
7.1-10.9	200-700	467.1	310.3	N/A	N/A	Torque Team® 5VF=0.242 x # ribs
	701-1250	393.5	260.7	N/A	N/A	
	1251-1900	347.1	239.9	N/A	N/A	
	1901-3000	340.7	225.5	N/A	N/A	
11.8-16.0	200-700	604.7	401.5	N/A	N/A	
	701-1250	527.9	348.7	N/A	N/A	
	1251-2100	505.5	335.9	N/A	N/A	
8VF Cross Section						
12.5-20.0	200-500	1008.4	670.8	N/A	N/A	Torque Team® 8VF=0.603 x # ribs
	501-850	861.2	571.6	N/A	N/A	
	851-1150	781.2	518.8	N/A	N/A	
	1151-1650	739.6	491.6	N/A	N/A	
21.2-25.0	200-500	1517.2	1010.0	N/A	N/A	
	501-850	1405.2	934.8	N/A	N/A	
	851-1200	1304.4	867.6	N/A	N/A	

*Multiply table values by the number of Torque Team® ribs to achieve recommended tensioning value.

1. The table deflection forces and strand tensions are typically at maximum values to cover the broad range of loads, rpm and pulley combinations for all possible drives.
2. For drives where hub loads are critical, high speed drives or other drives with special circumstances, the belt deflection force and strand installation tension should be calculated by using formulas found in existing engineering manuals or use the MaximizerPro™ Drive Selection Analysis Program.
3. Consult the TensionRite® Belt Frequency Meter manual for detailed information on using the frequency-based tension gauge.
4. Continental ContiTech offers three different levels of tension gauges to aid in properly tensioning power transmission belts. See your Sales Representative or Distributor for more information on tensioning gauges.

WARNING

DO NOT USE THE PRODUCTS IN THIS GUIDE IN AIRCRAFT APPLICATIONS. THE PRODUCTS IN THIS GUIDE ARE NOT INTENDED FOR USE IN AIRCRAFT APPLICATIONS.

DO NOT USE THE PRODUCTS IN THIS GUIDE IN LIFT OR BRAKE SYSTEMS WHICH DO NOT HAVE AN INDEPENDENT SAFETY BACKUP SYSTEM. THE PRODUCTS IN THIS GUIDE ARE NOT INTENDED FOR USE IN LIFT OR BRAKE SYSTEMS WHICH DO NOT HAVE AN INDEPENDENT SAFETY BACKUP SYSTEM.

FAILURE TO FOLLOW THESE WARNINGS AND THE PROPER PROCEDURES FOR SELECTION, INSTALLATION, CARE, MAINTENANCE AND STORAGE OF BELTS MAY RESULT IN THE BELT'S FAILURE TO PERFORM PROPERLY AND MAY RESULT IN DAMAGE TO PROPERTY AND/OR SERIOUS INJURY OR DEATH.

The products in this guide have been tested under controlled laboratory conditions to meet specific test criteria. These tests are not intended to reflect performance of the product or any other material in any specific application, but are intended to provide the user with application guidelines. The products are intended for use by knowledgeable persons having the technical skills necessary to evaluate their suitability for specific applications. Continental ContiTech assumes no responsibility for the accuracy of this information under varied conditions found in field use. The user has responsibility for exercising care in the use of these products.

Notice on static conductivity: Drive conditions and service variables in combination with time in operation can result in loss of static conductivity. It is recommended that a conductivity check be added to drive preventative maintenance programs where belt static conductivity is a requirement. For more information on static conductivity, visit us at www.contitech.us.

Tools

Installation Guide

Drive Maintenance Materials

Items	SAP#
TensionRite® Belt Frequency Meter	20287454*
TensionRite® Optical Head Replacement	20545642*
TensionRite® Large Tension Tester (Instructions included)	20083777*
TensionRite® Small Tension Tester (Instructions included)	20044882*
Laser Alignment Tool	20245089*
Laser Alignment Tool Replacement Magnet	20304774*

*Contact your Distributor.

**EPIX users can order through GBS, otherwise, contact your Sales Representative.

For availability, contact your
Distributor or call Customer Service
at 1-800-235-4632.



Now Web Enabled

With instant online access at www.contitech.us/maxpro. No download required.

Experience the E's of our Efficiency Program

We are committed to helping you improve your bottom line by saving on energy costs. With maintenance tools, specialized training and a team of drive systems specialists from Continental ContiTech, we will help ensure your drive system runs as efficiently as possible. Because when your systems operate at their best, you save green.



ContiTech



Contact

ContiTech AG
NAFTA Headquarters
703 S. Cleveland Massillon Road
Fairlawn, OH 44333-3023 U.S.A.
1-800-235-4632

Canada

1-888-275-4397
FAX 1-888-464-4397

Mexico

1-800-439-7373
FAX 1-800-062-0918

Germany

+49 (0)511 938 02
mailservice@contitech.de

www.contitech.us

ContiTech. Engineering Next Level

As a division of the Continental Group, ContiTech is a recognized innovation and technology leader in natural rubber and plastics. As an industry partner with a firm future ahead of us, we engineer solutions both with and for our customers around the world. Our bespoke solutions are specially tailored to meet the needs of the market. With extensive expertise in materials and processes, we are able to develop cutting-edge technologies while ensuring we make responsible use of resources. We are quick to respond to important technological trends, such as function integration, lightweight engineering and the reduction of complexity, and offer a range of relevant products and services. That way, when you need us, you'll find we're already there.